



Growing an Internet Exchange Point

From a small community initiative to one of the larger interconnection points in the world

Henk Steenman
Henk.Steenman@ams-ix.net

Agenda

- ▶ Introduction
 - ▶ Current state of the AMS-IX
 - ▶ Growing a community based Internet Exchange Point
 - ▶ Evolution of AMS-IX

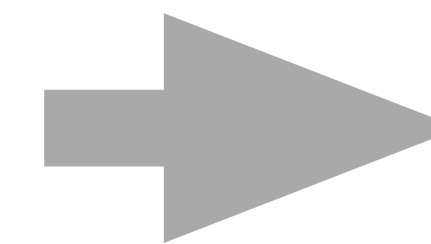
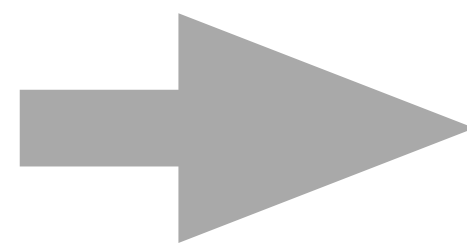

AMS-IX Topology Map

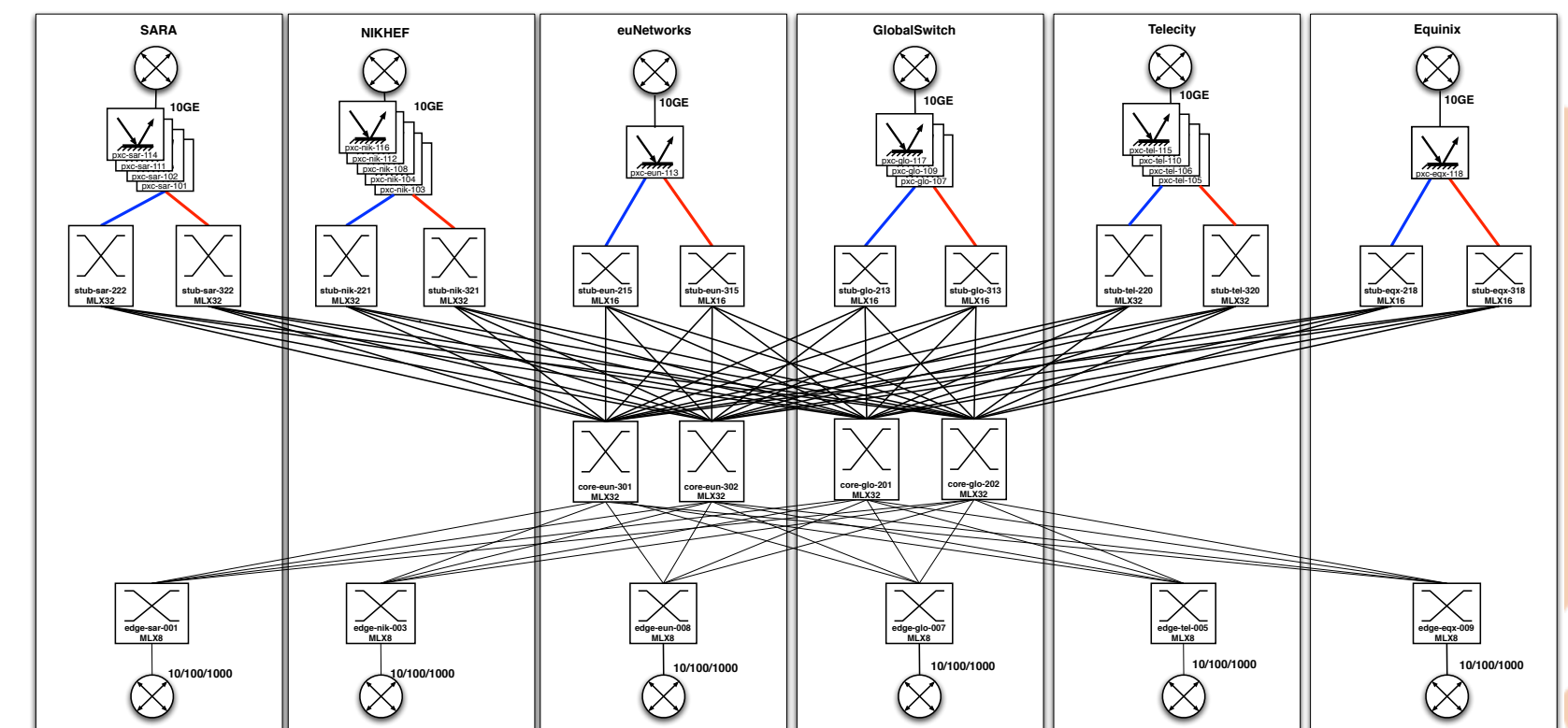
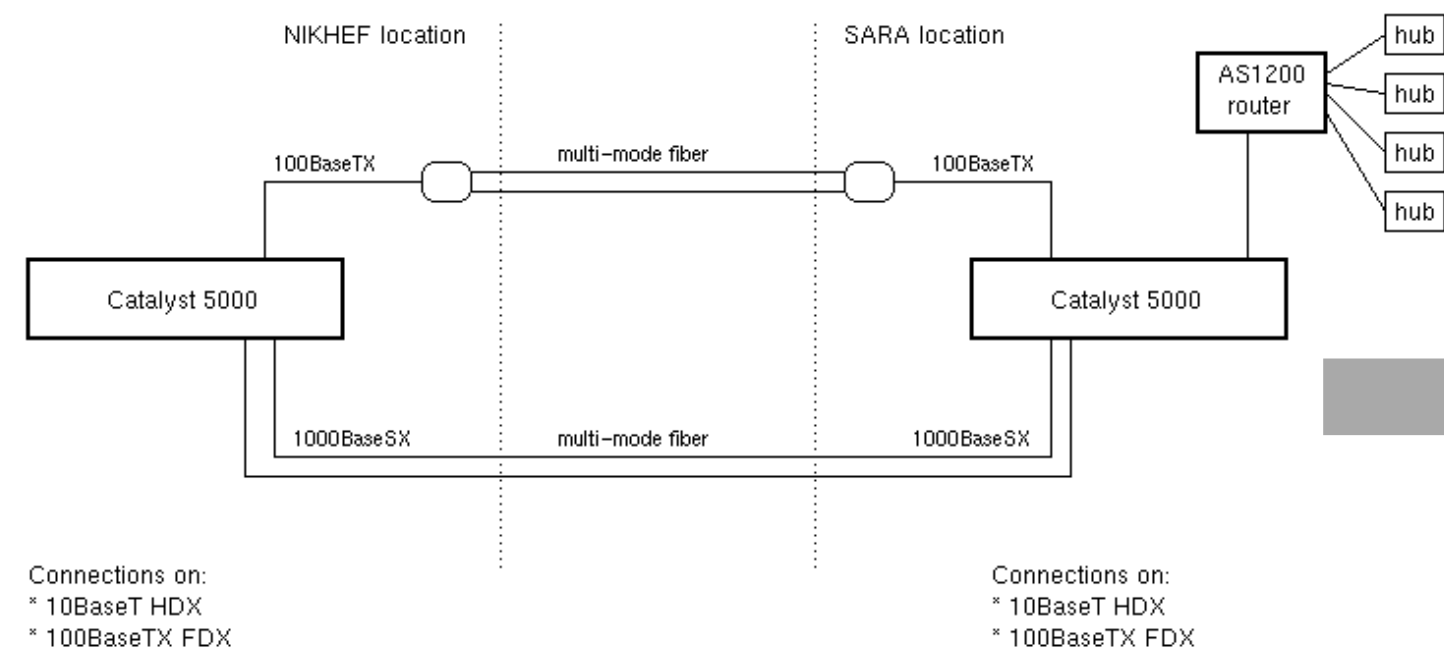

Introduction

AMS-IX Association and Limited Liability Company

From the Articles of the AMS-IX Association

1. The objective of the Association is to facilitate the exchange of (internet-)transactions and everything that contributes thereto in the broadest sense of the word. The Association does thereby not strive to make any profit
2. The Association tries to achieve this objective amongst others by providing directly or indirectly a connection to the Amsterdam Internet Exchange to the members of the Association

Limited Liability Company

- ▶ Single shareholder (the AMS-IX Association)
- ▶ Same objective as Association

Introduction

AMS-IX Association and Limited Liability Company

- ▶ Members: <http://www.ams-ix.net/connected/>
- ▶ Requirements to become a member on the ISP VLAN
 - ▶ Be a legal entity
 - ▶ Have an officially assigned AS number (by one of the RIRs)
 - ▶ Sign Connection agreement (contract between AMS-IX BV and member)
 - ▶ <http://www.ams-ix.net/connecting/steps/connagr.pdf>
 - ▶ Member arranges co-location facilities and/or all necessary means to connect to AMS-IX demarcation point

Introduction

The AMS-IX Governance Structure

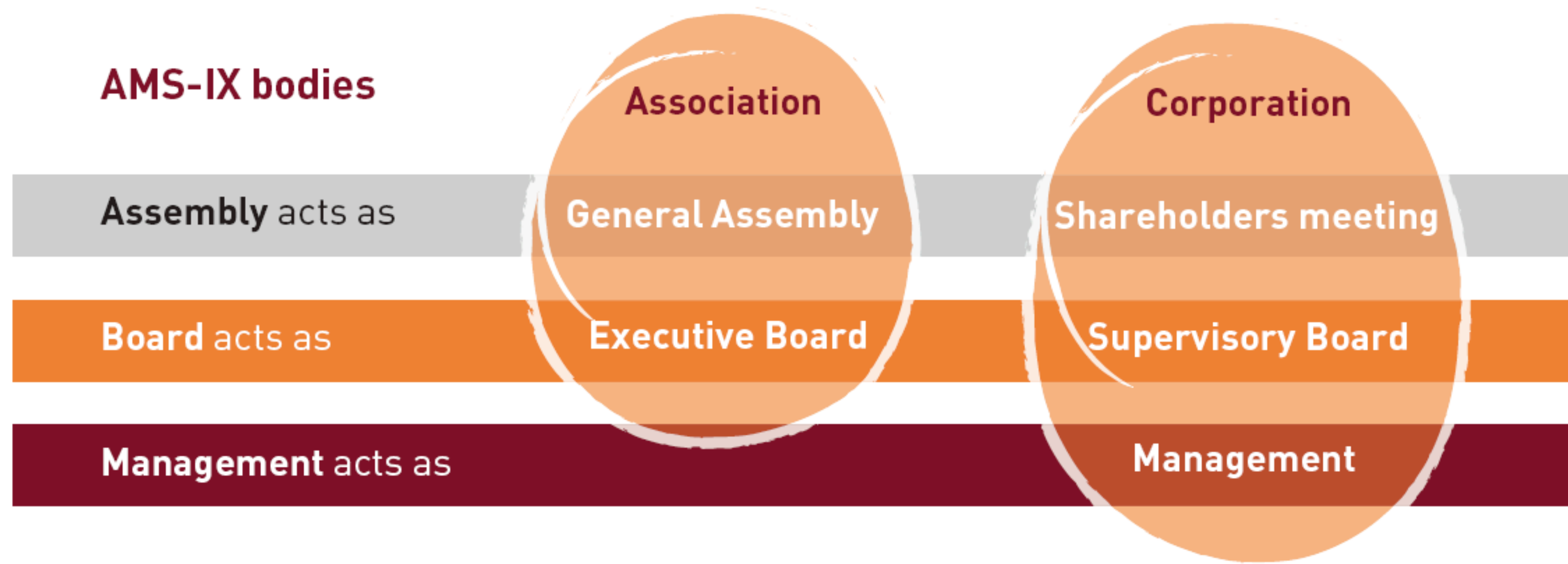

- ▶ The Board has 5 seats and is elected by the members, out of member representatives, in the General Meeting

Introduction

AMS-IX Platform Topology Oct 2009

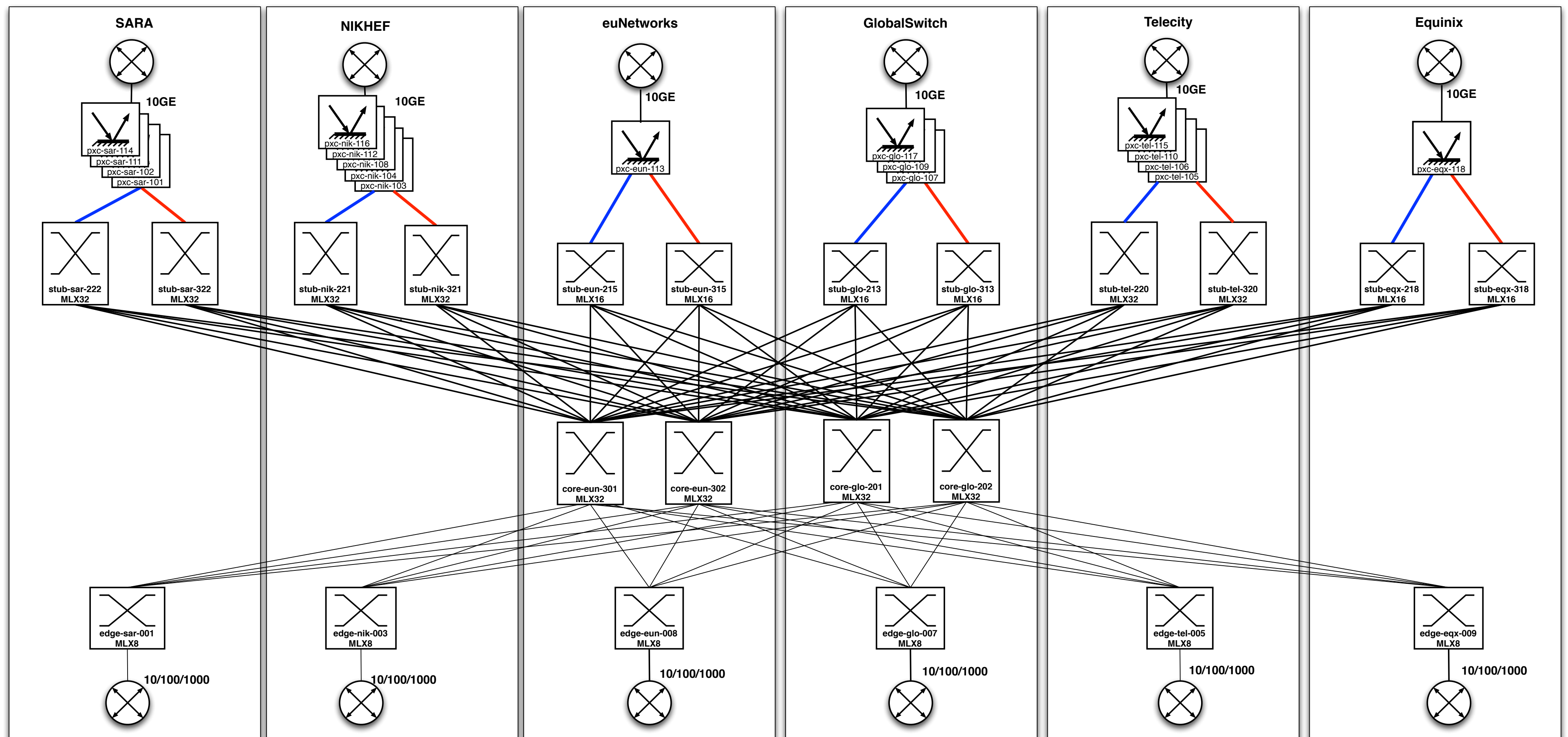

Introduction

Member Traffic

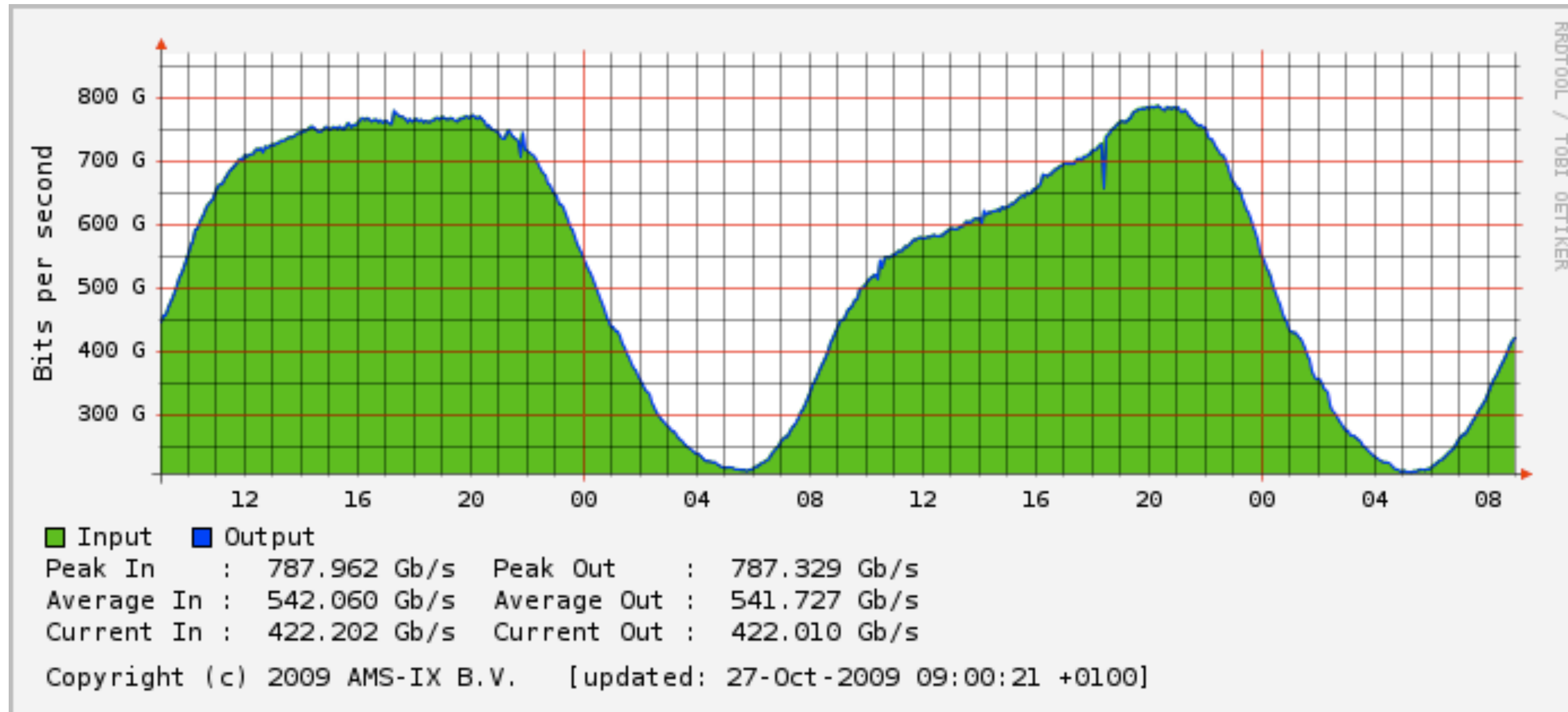

Introduction

Member Traffic

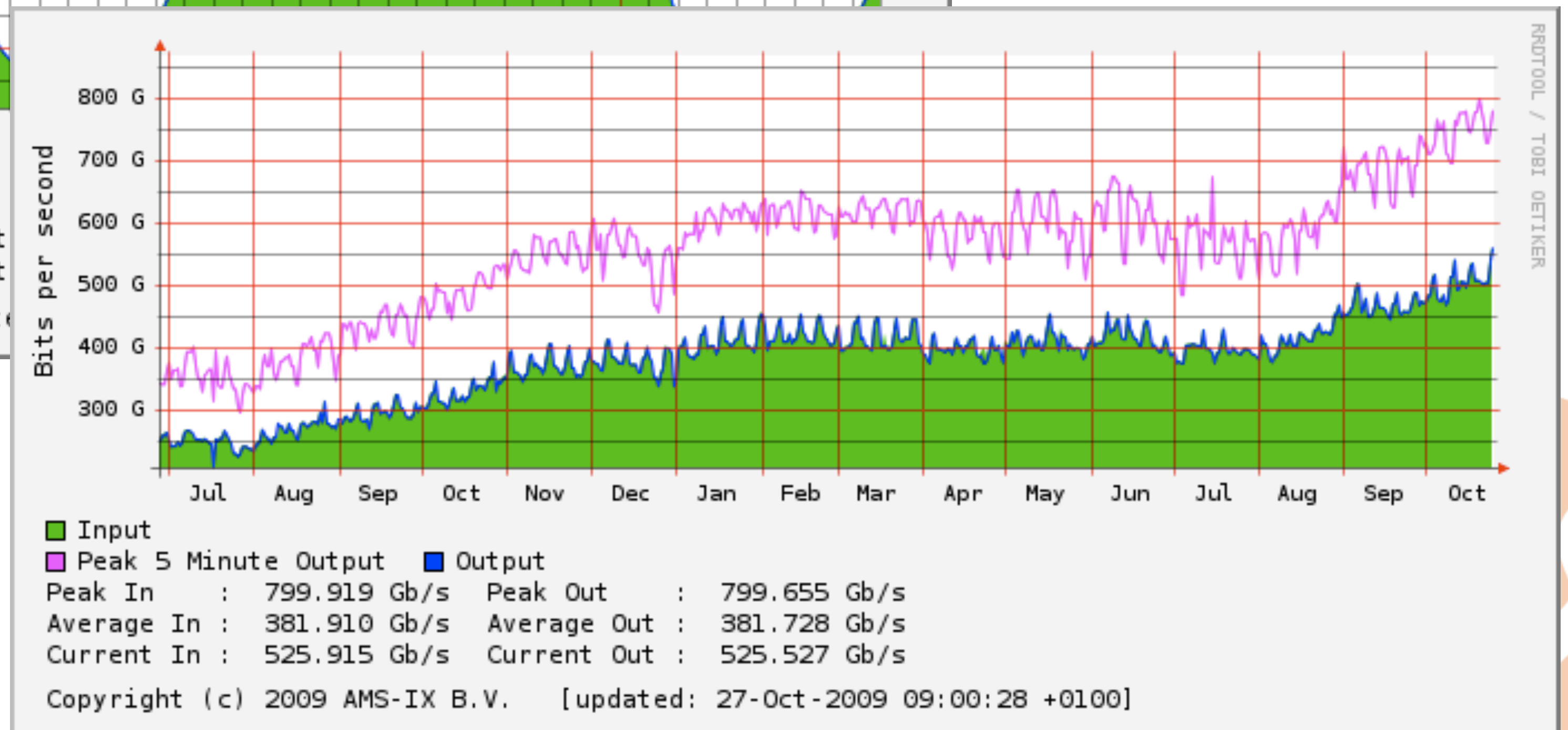
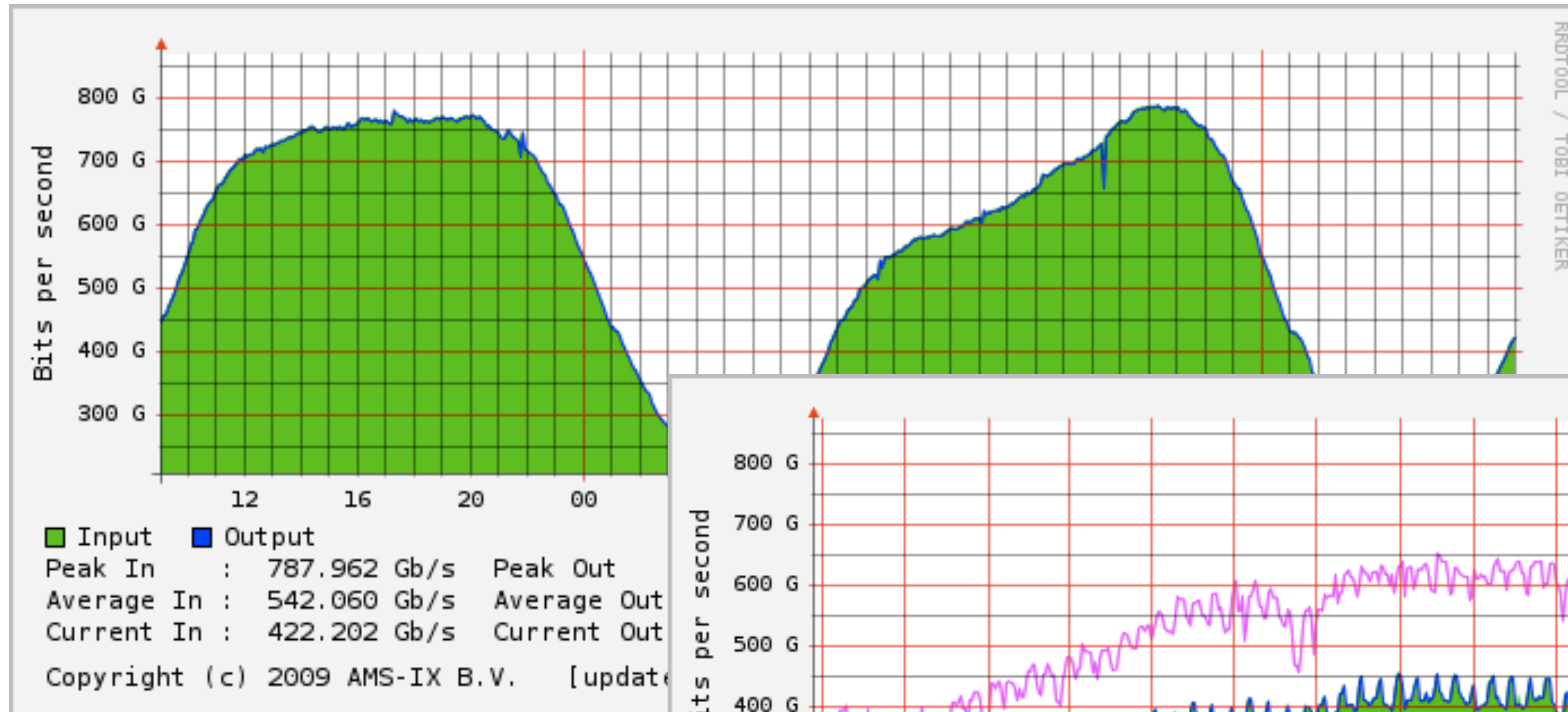

Average and Peak traffic

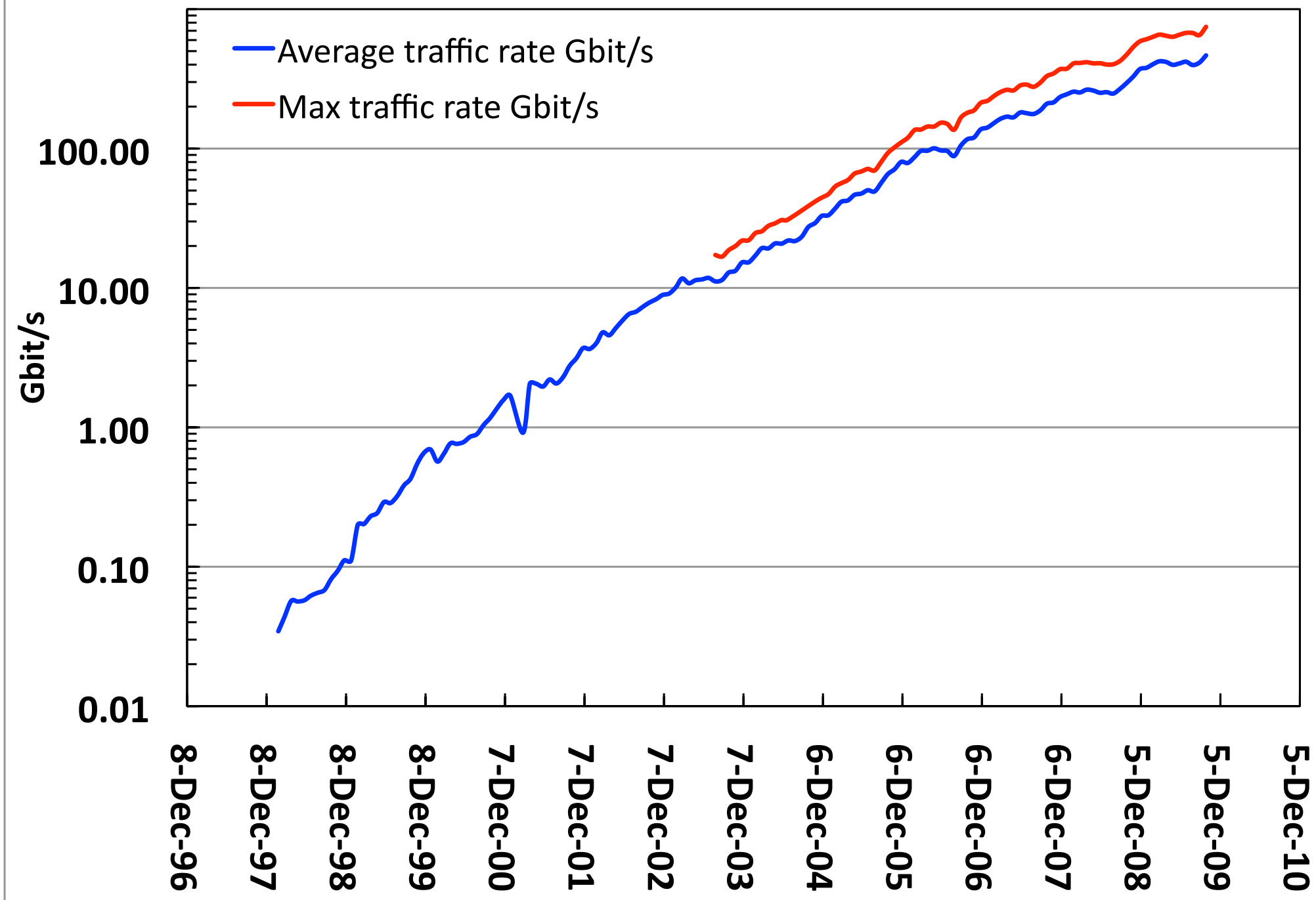

Traffic Volume Tbyte/day

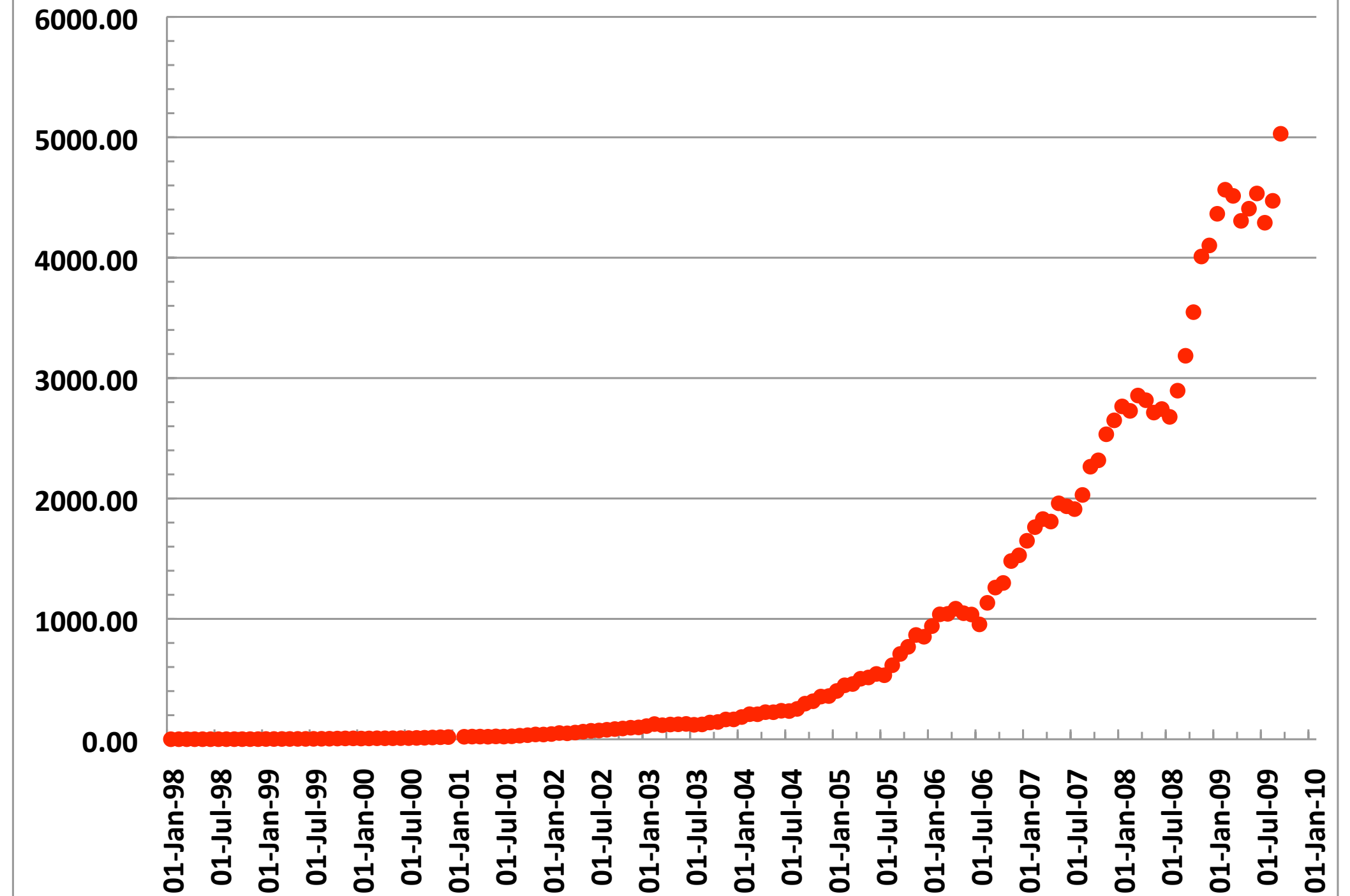

Introduction

Historical Traffic Growth



Traffic Volume Tbyte/day

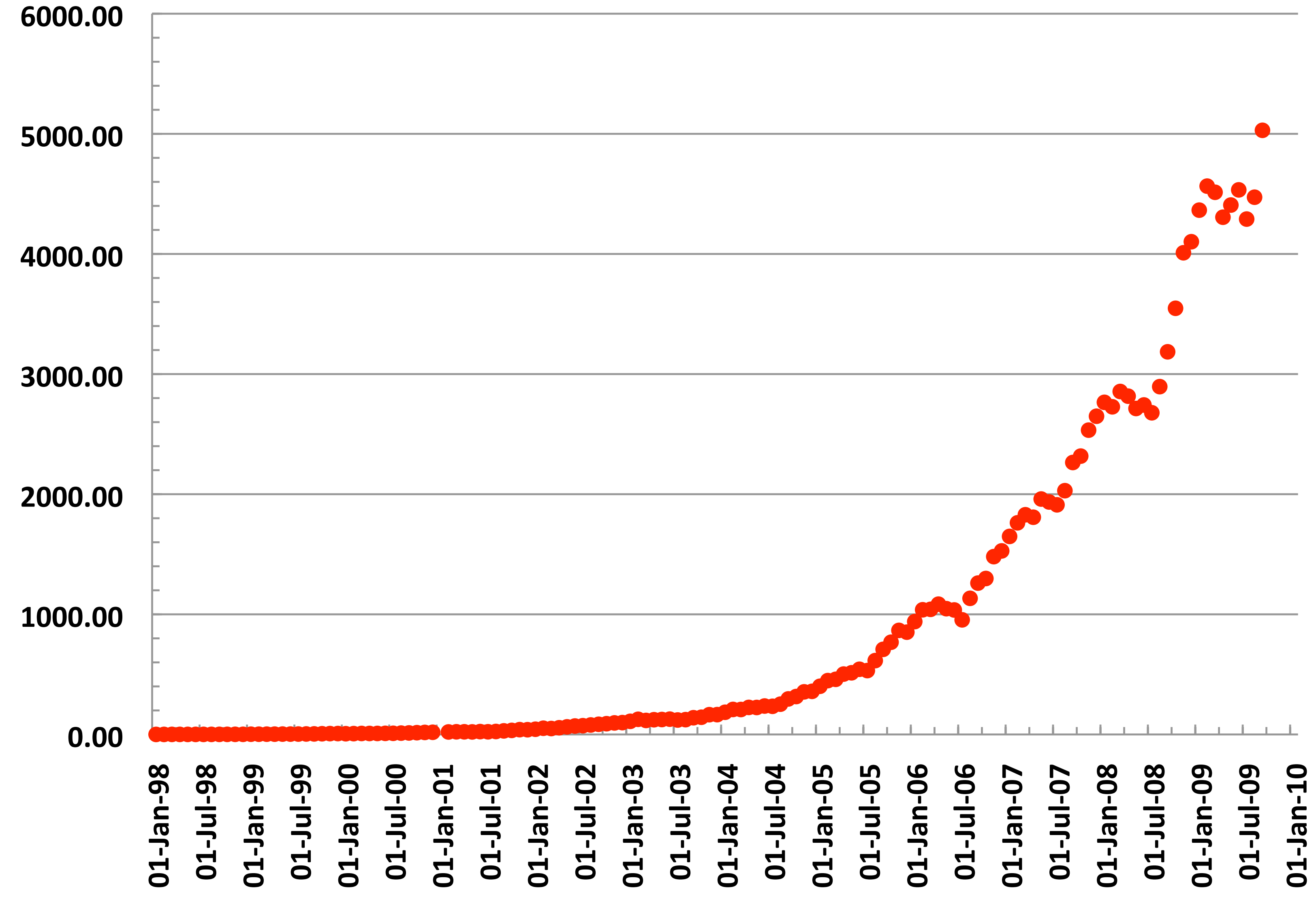
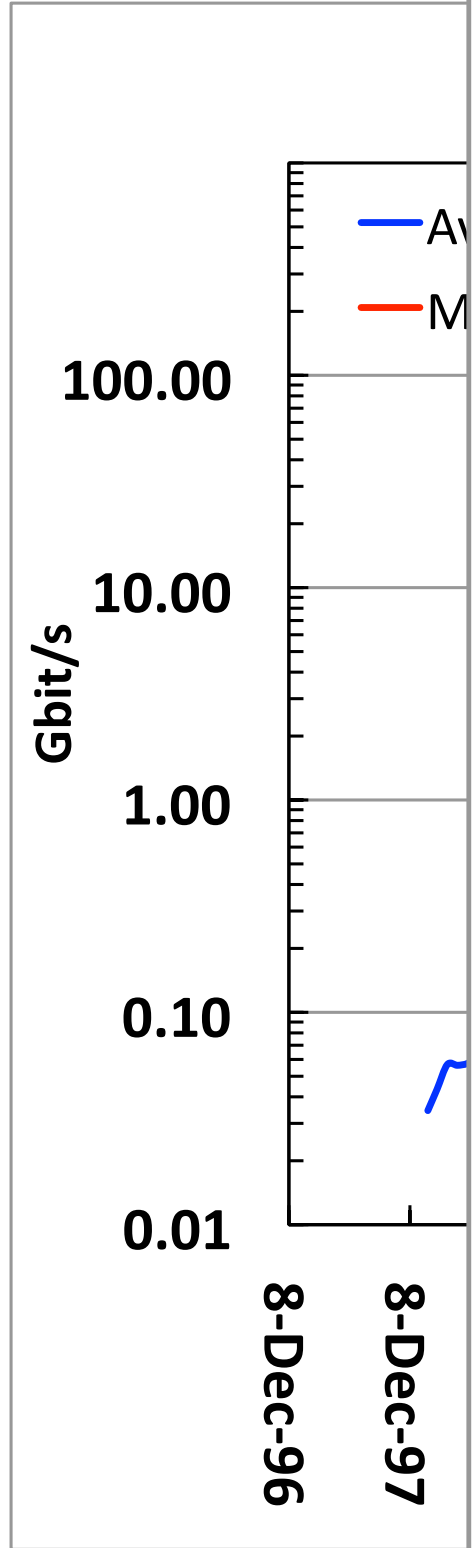

Historical Traffic Growth



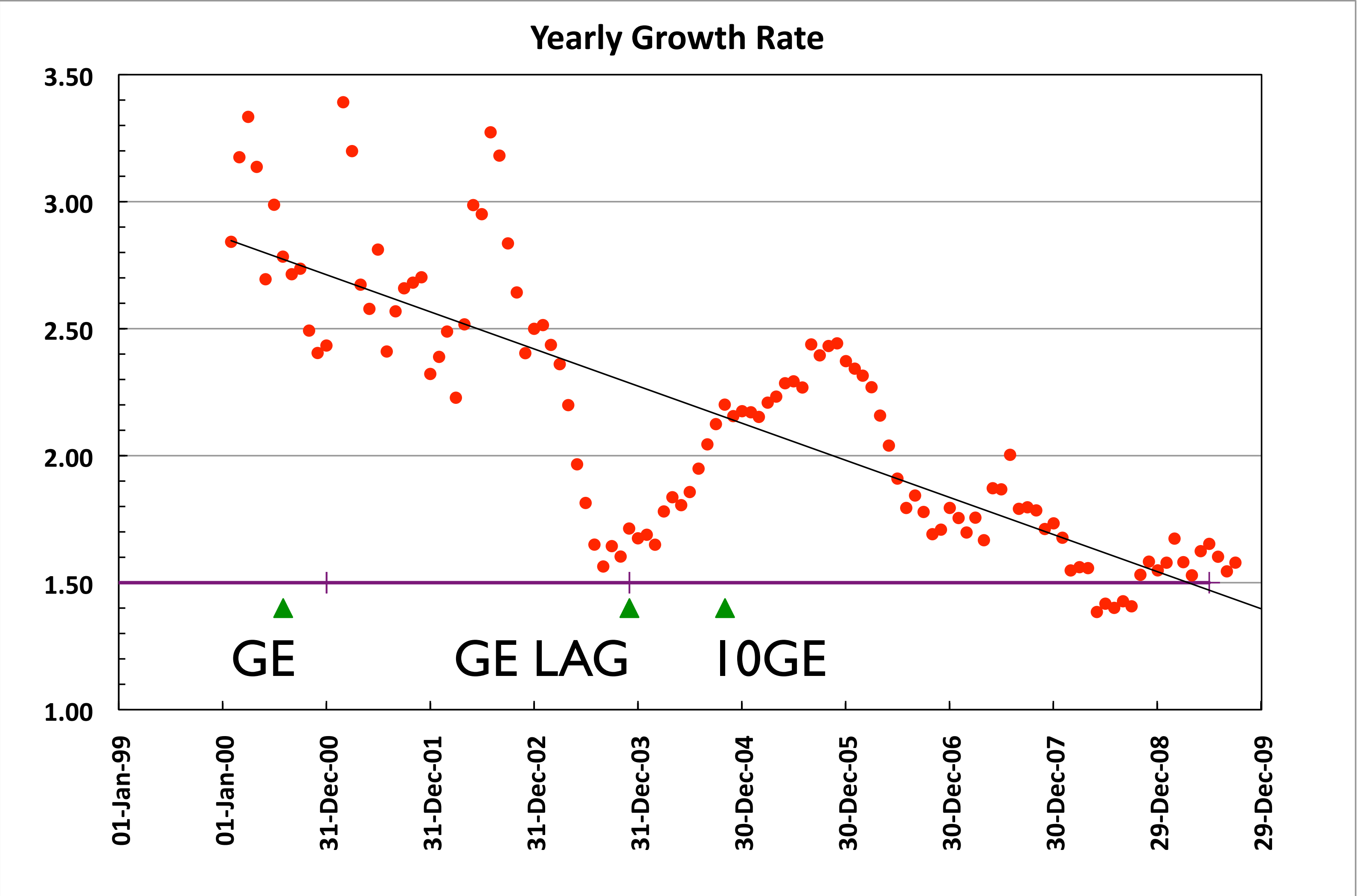

Introduction

Yearly Traffic Growth



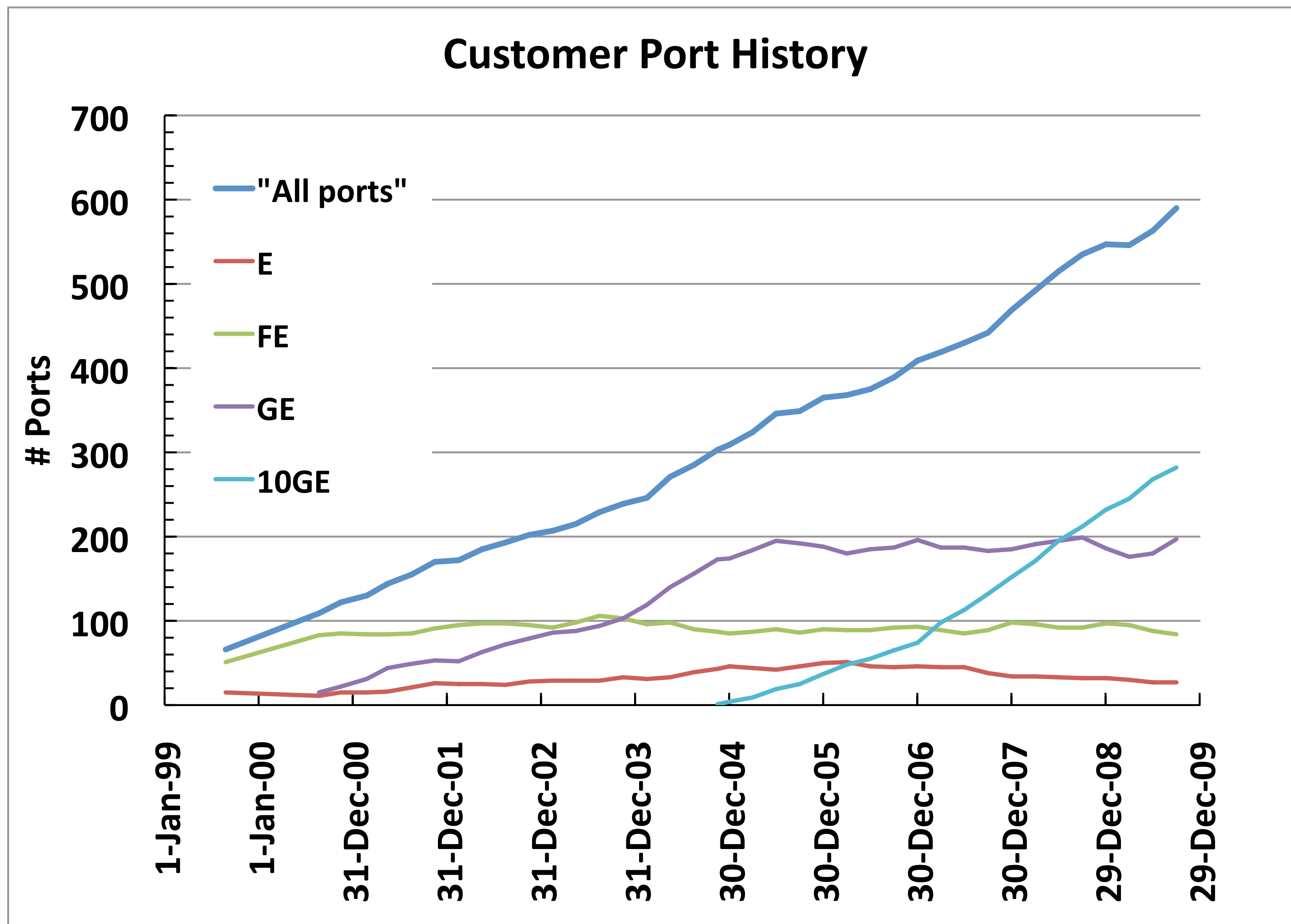

AMS-IX Historical Port Growth



10GE LAG size distribution

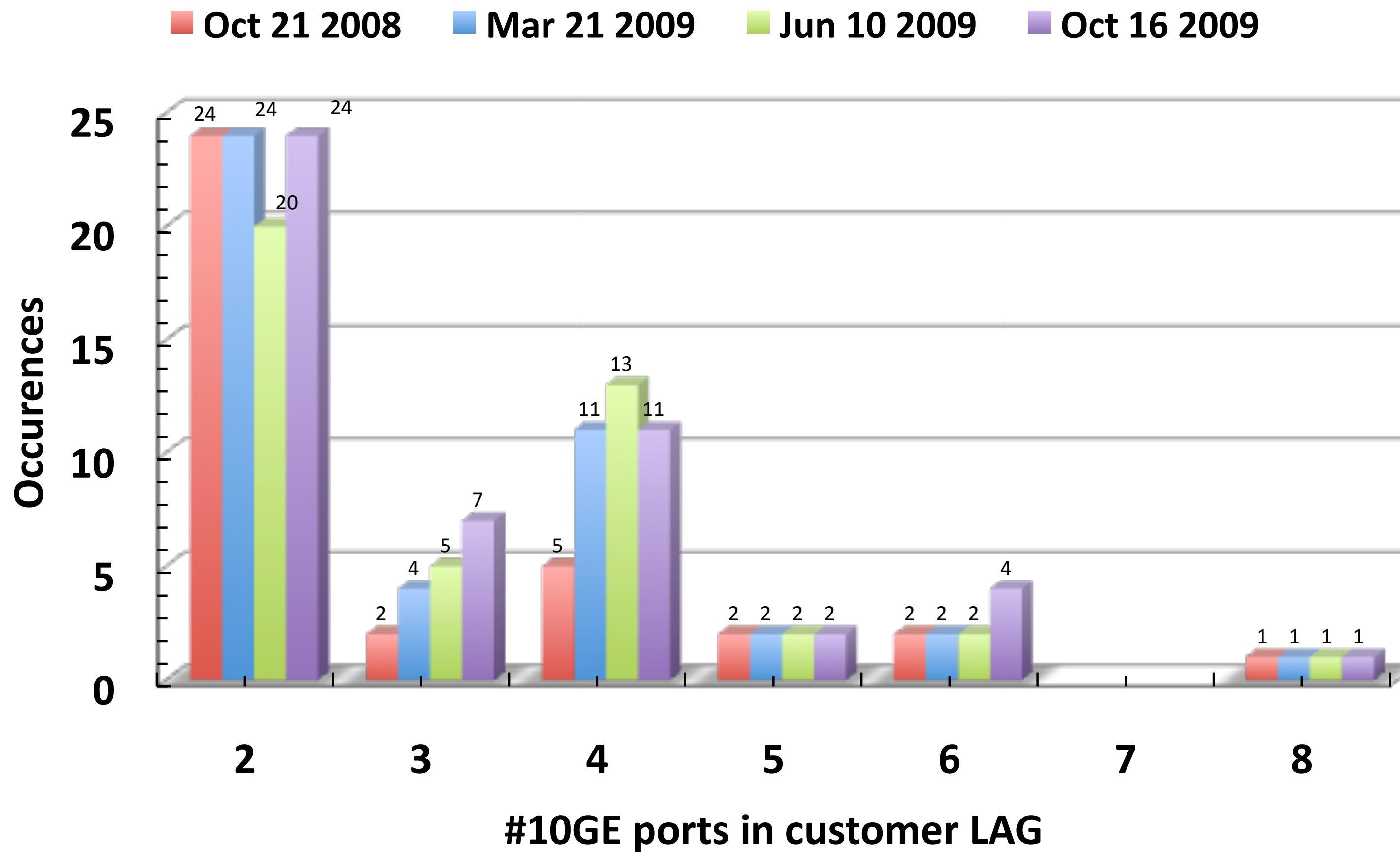

10GE LAG-size distribution



Evolution

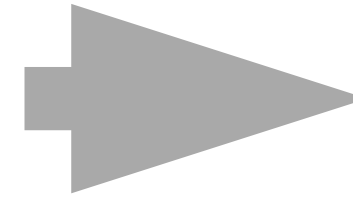
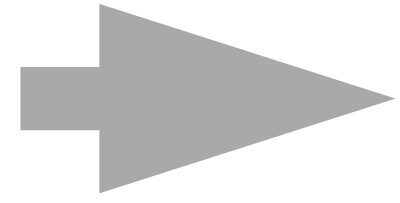

- ▶ Basis of AMS-IX success from day 1:
 - ▶ *Neutral, Impartial and Independent*
 - ▶ All participants have equal rights/vote/pricing etc
 - ▶ AMS-IX is not dependent on any of the participating (rival) companies
 - ▶ *Not for profit*
 - ▶ *Very limited rule-set to connect*
 - ▶ Be legal entity
 - ▶ Have AS number



Evolution

The Early Days

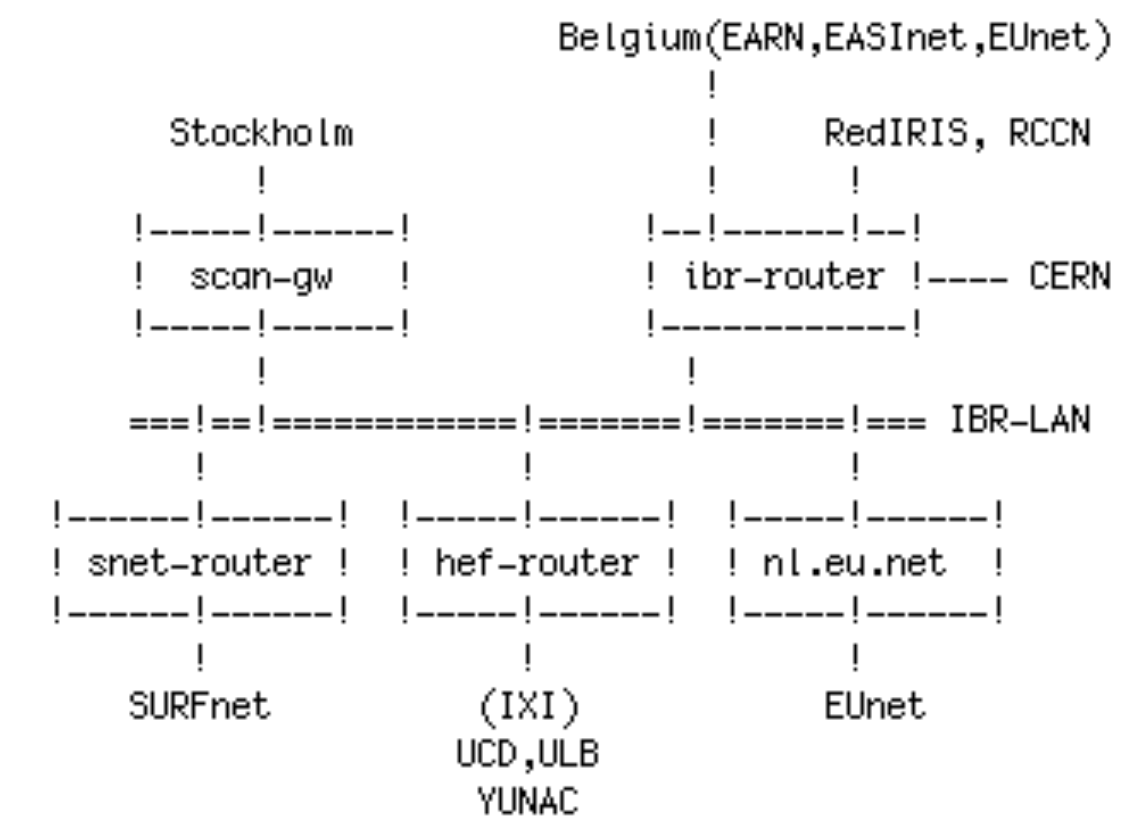

- ▶ Support of neutral/impartial organisation critical to initial success
- ▶ Participants are competitors by nature
- ▶ Dutch Academic Research Network, SURFnet took this role in the early 1990s
 - ▶ Administrative and operational management
 - ▶ Connection agreement was signed between the ISP and SURFnet
 - ▶ Technical management of the platform was outsourced to SARA (Academic computing center Amsterdam)
- ▶ AMS-IX has taken a similar role at CAR-IX



Evolution

The Early Days

Amsterdam Internet Exchange: Announcement January 1994

Date: Fri, 07 Jan 94 15:10:49 +0100
From: Erik-Jan Bos <erik-jan.bos@SURFnet.nl>
To: Reseaux IP Europeens <ripe-list@ripe.net>
Subject: Announcement of the Amsterdam Internet Exchange

ANNOUNCEMENT OF THE AMSTERDAM INTERNET EXCHANGE

SURFnet hereby announces that resources will be made available to facilitate the establishment of the pilot Amsterdam Internet Exchange. It is planned to have a Route Server and Mbone facilities at the pilot Amsterdam Internet Exchange in operation on 1 February 1994. The pilot Amsterdam Internet Exchange will be available to all interested Internet service providers. The connections at the pilot Amsterdam Internet Exchange will be free of charge during 1994.

- ▶ Initially the Exchange (IBR-LAN) is a self organising group of companies with a common interest
- ▶ 1994 Announcement of AMS-IX on RIPE mailinglist
- ▶ 1996 First organised meeting of AMS-IX participants
 - ▶ Decision to keep regular meetings
- ▶ 1997 Meeting sets basic operating principles on how to operate the Exchange and defines basis for the Association



Evolution

Basic operating principles

Date: Monday, 23 September 1996
Time: 11:00 - 12:30 hrs
Place: NIKHEF meeting room H320, Amsterdam, The Netherlands
Status: Final

Participants:

Name	Affiliation	E-mail address
Henk Steenman	AT&T EMEA	henk@att.nl
Peter Galbavy	Demon Internet	peter@demon.net
Nick Reid	Demon Internet	nickr@demon.net
Kurt Kayser	ECRC/Ebone	kurt@ecrc.de
Lars-Johan Liman	Ebone	liman@sunet.se
Patrick de Bock	Global One	patrick.debock@global-one.nl
Henry Steuart	Global One	hsteuart@hq.si.net
Job Witteman	Global One	job.witteman@global-one.nl
Rob Blokzijl	NIKHEF	k13@nikhef.nl
Ted Lindgreen	NLnet	ted@nl.net
Geert Jan de Groot	RIPE NCC	geertjan.degroot@ripe.net
Daniel Karrenberg	RIPE NCC	dfk@ripe.net
Willem van der Scheun	SARA	scheun@sara.nl
Jan Hondebrink	SARA	janh@sara.nl
Walter van Dijk	SURFnet	walter.vandijk@surfnet.nl
Erik-Jan Bos	SURFnet	bos@surfnet.nl
Nick Vermeulen	Wirehub! Internet	nick@wirehub.net

2. AMS-IX status report

Walter van Dijk reported on the parties connected to the AMS-IX. Currently, 12 ISPs and the RIPE NCC are connected and 4 more ISPs are in the process of getting connected.

- ▶ It is essential that AMS-IX operates financially independent from all participating ISPs
- ▶ A structure of ISPs working together as a common goal is considered the best way forward
- ▶ Rules on admission and conflict resolution should be formulated by all participants in yearly participants meeting
- ▶ An Executive committee chosen from the participants (5 persons) should take care of day to day matters
- ▶ Day to day operational work to be outsourced to subcontractor



Evolution

Formalising The Organisation



Organisation becomes more mature

- ▶ Dec 1997 Establishment of the AMS-IX Association
- ▶ May 1999 Task Force of Members and Exec to define AMS-IX at 2000+
 - ▶ Create independent body to manage the Exchange
 - ▶ Expand to new co-locations
 - ▶ More colocations => More choice for members
 - ▶ Change of switch hardware vendor
- ▶ Dec 1999 AMS-IX Limited Liability Company established
- ▶ Jan 2002 AMS-IX NOC for in-house operational management
- ▶ Summer 2003 Marketing and Customer relations department

Sep 1996 13 members

AMS-IX Topology Map

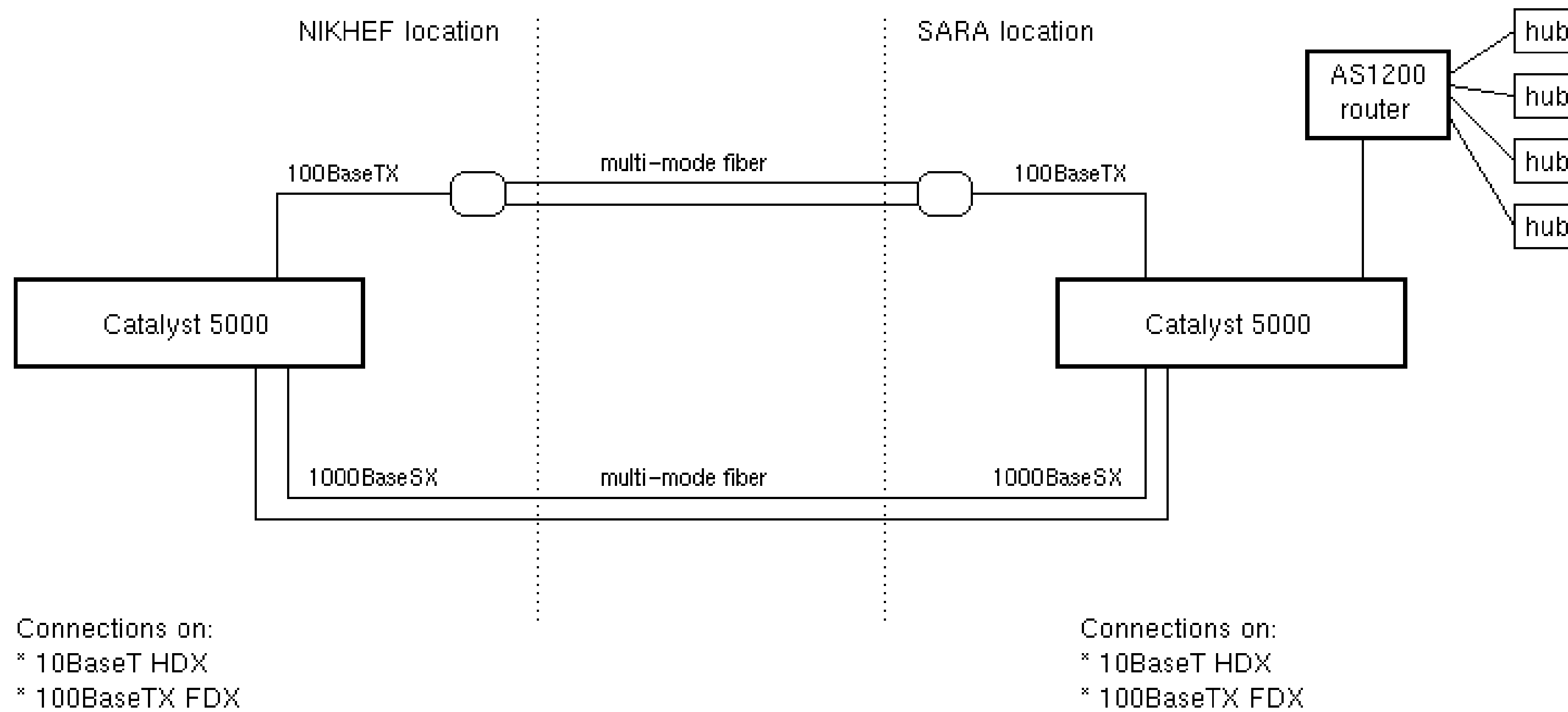

AMS-IX Platform Evolution

Version 1.0 - 1996 to Q3 2000



Sep 1996 13 members

Dec 2000 108 members

AMS-IX Topology Map

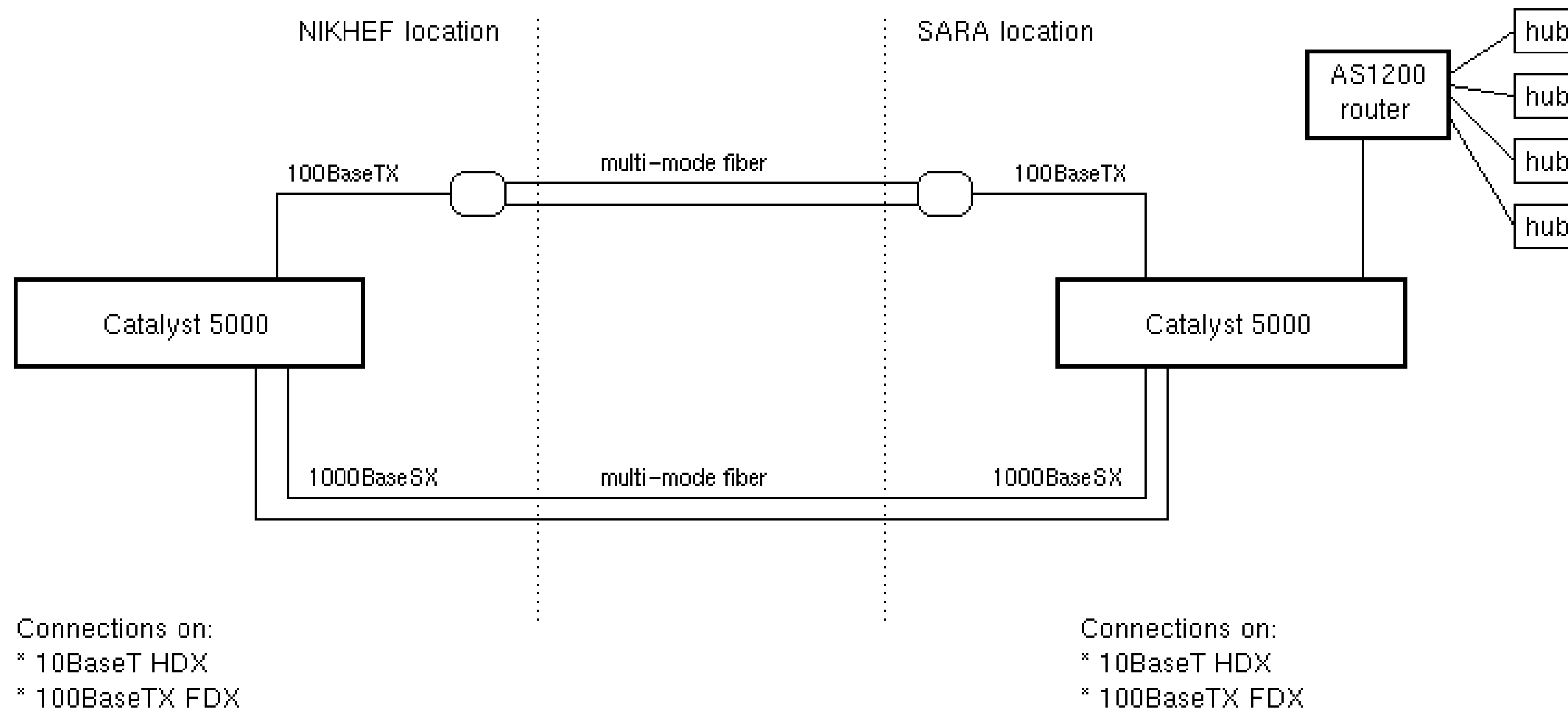

AMS-IX Platform Evolution

Version 1.0 - 1996 to Q3 2000



Sep 1996 13 members

Dec 2000 108 members

AMS-IX Topology Map

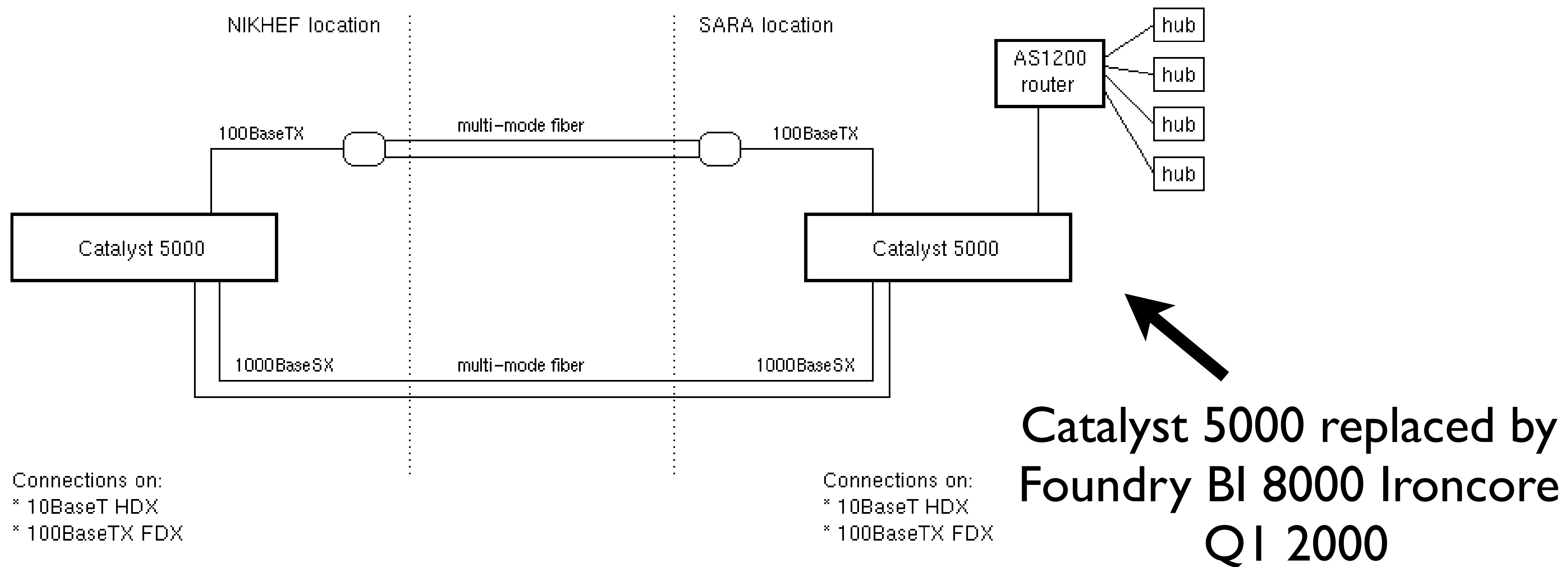

AMS-IX Platform Evolution

Version 1.0 - 1996 to Q3 2000



Sep 1996 13 members

Peak traffic 3 Gbit/s Dec 2000

Dec 2000 108 members

AMS-IX Topology Map

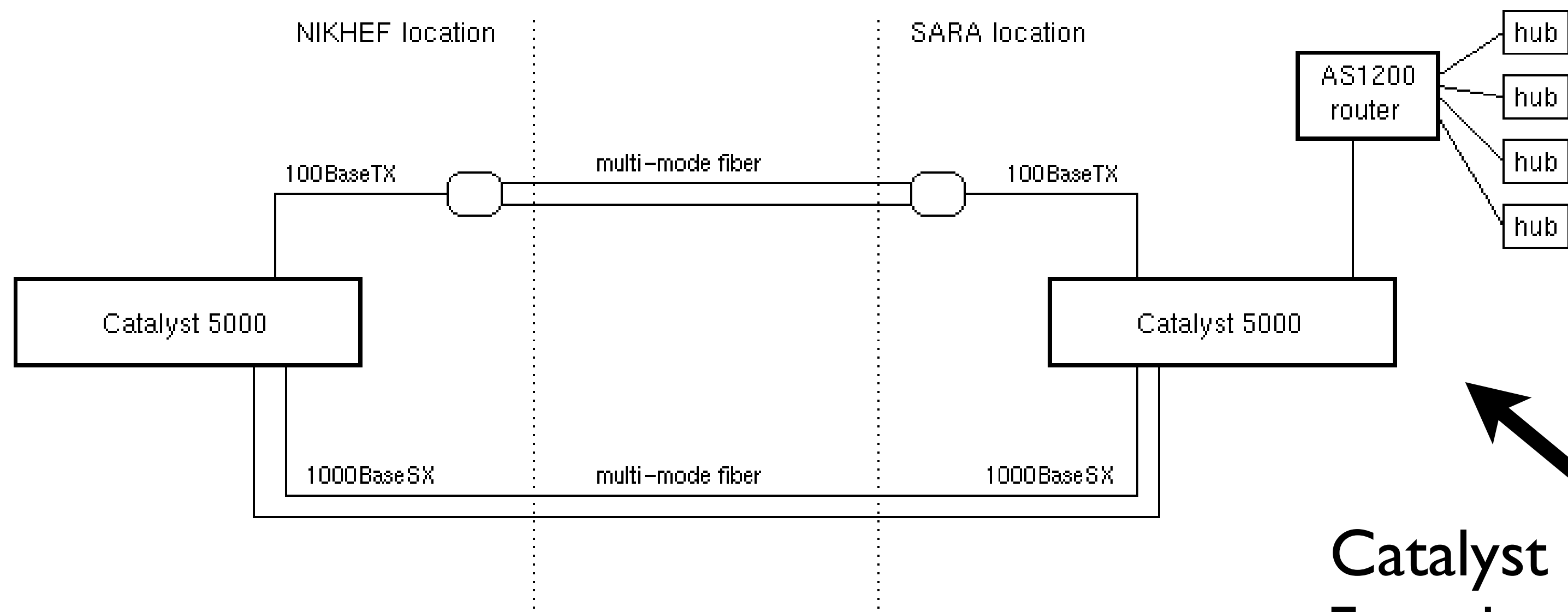

Connections on:
 * 10BaseT HDX
 * 100BaseTX FDX

Connections on:
 * 10BaseT HDX
 * 100BaseTX FDX

Catalyst 5000 replaced by
Foundry BI 8000 Ironcore
QI 2000

AMS-IX Platform Evolution

Version 1.0 - 1996 to Q3 2000



Sep 1996 13 members

Peak traffic 3 Gbit/s Dec 2000

Dec 2000 108 members

AMS-IX Topology Map

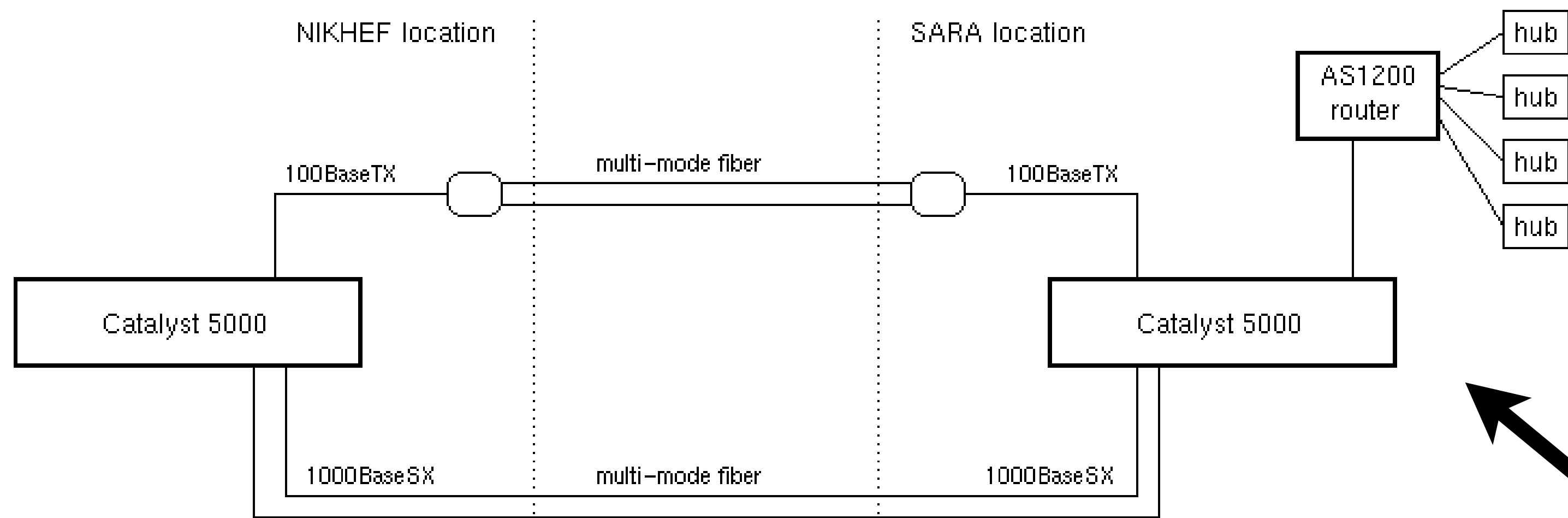

Connections on:
 * 10BaseT HDX
 * 100BaseTX FDX

Connections on:
 * 10BaseT HDX
 * 100BaseTX FDX

Catalyst 5000 replaced by
Foundry BI 8000 Ironcore
QI 2000

Peak load ISL Q4 2000 500 Mbit/s

AMS-IX Platform Evolution

Version 1.0 - 1996 to Q3 2000



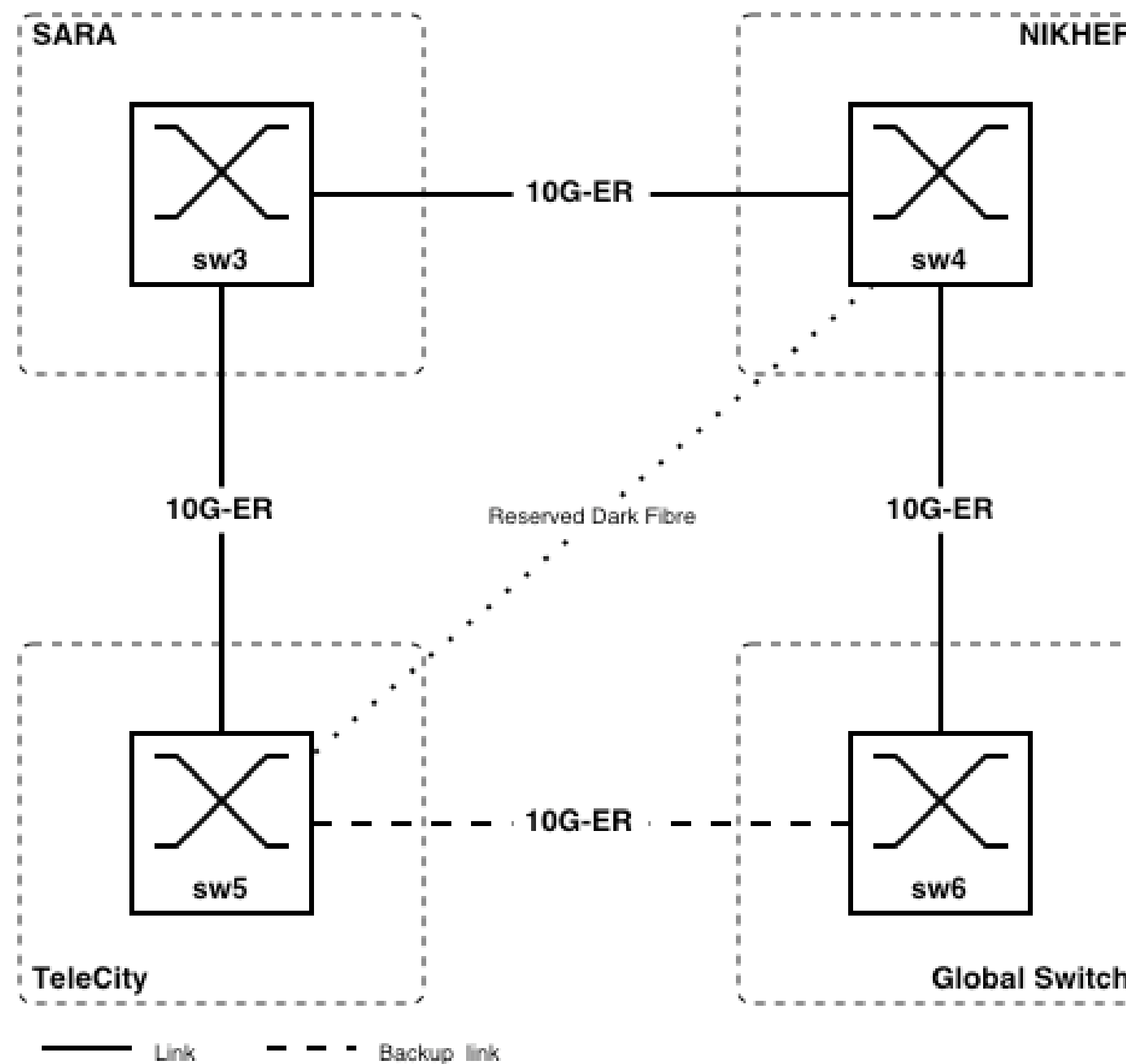

AMS-IX Platform Evolution

Version 2.0 - Q1 2001 to Q4 2003



(R)STP loop protection protocol

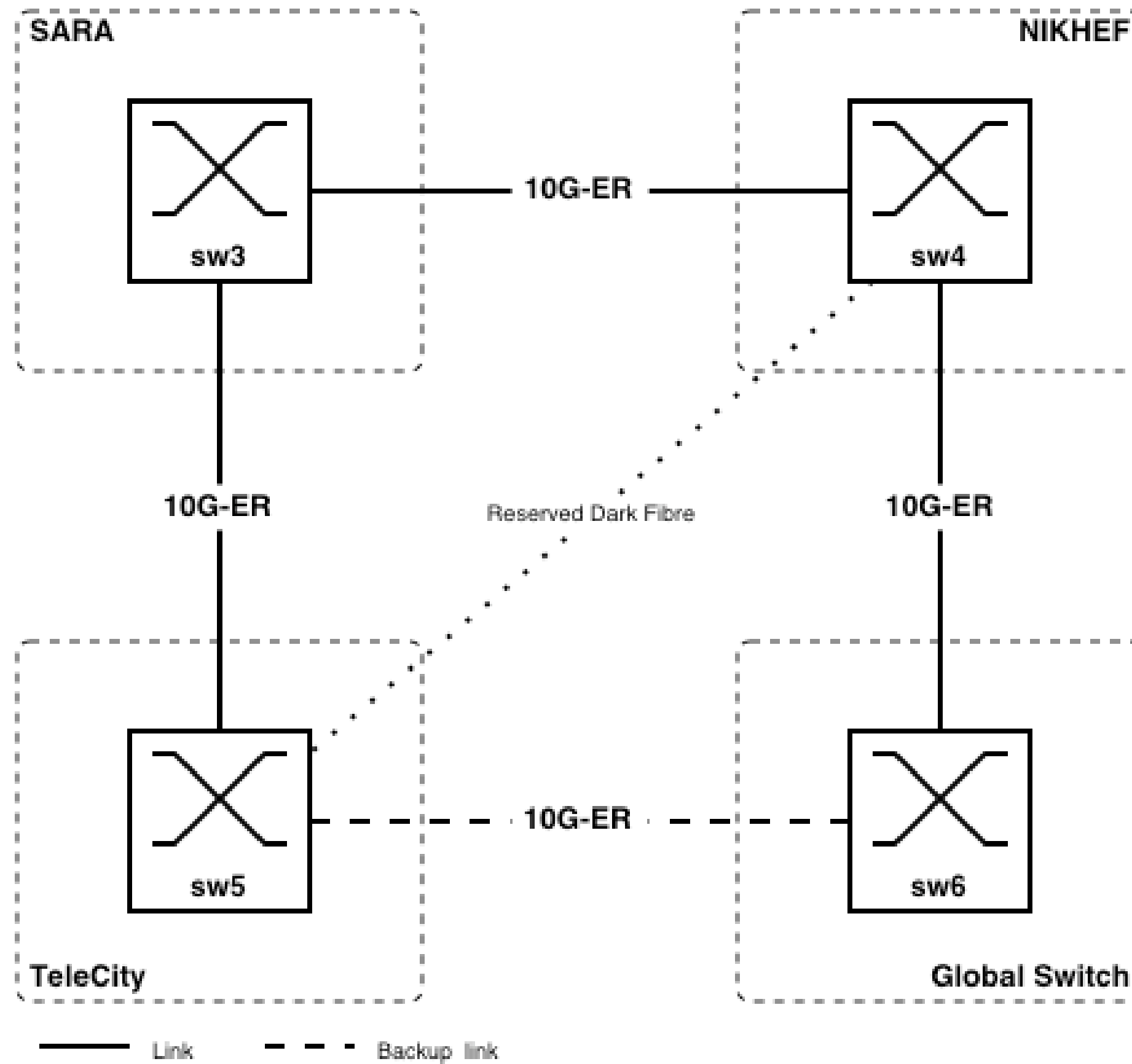

AMS-IX Platform Evolution

Version 2.0 - Q1 2001 to Q4 2003



(R)STP loop protection protocol

Backbone links upgraded from GE to 10GE End 2002

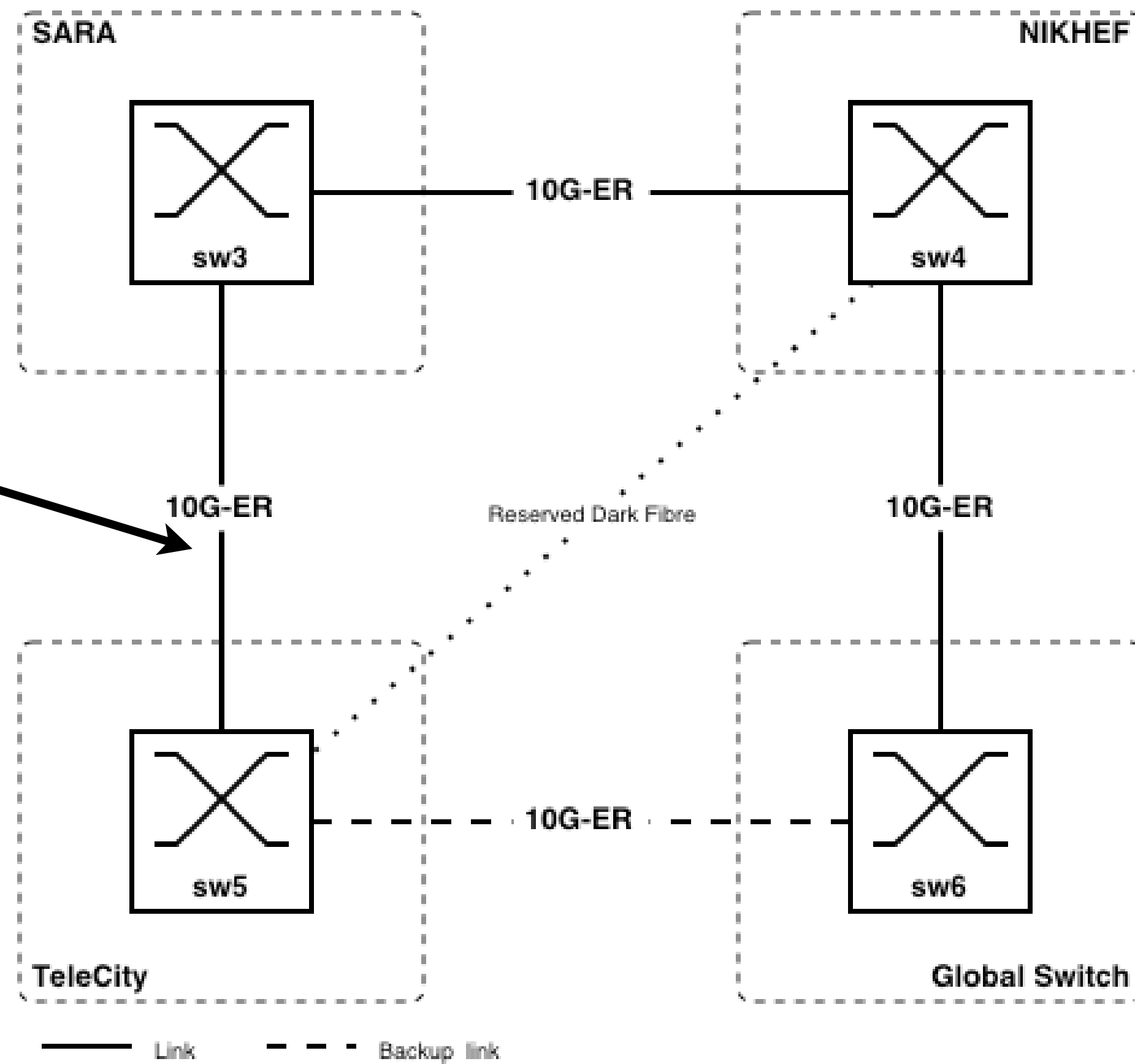

AMS-IX Platform Evolution

Version 2.0 - Q1 2001 to Q4 2003



(R)STP loop protection protocol

Backbone links upgraded from GE to 10GE End 2002

End 2003 Upgrade to BI-15000 JetCore

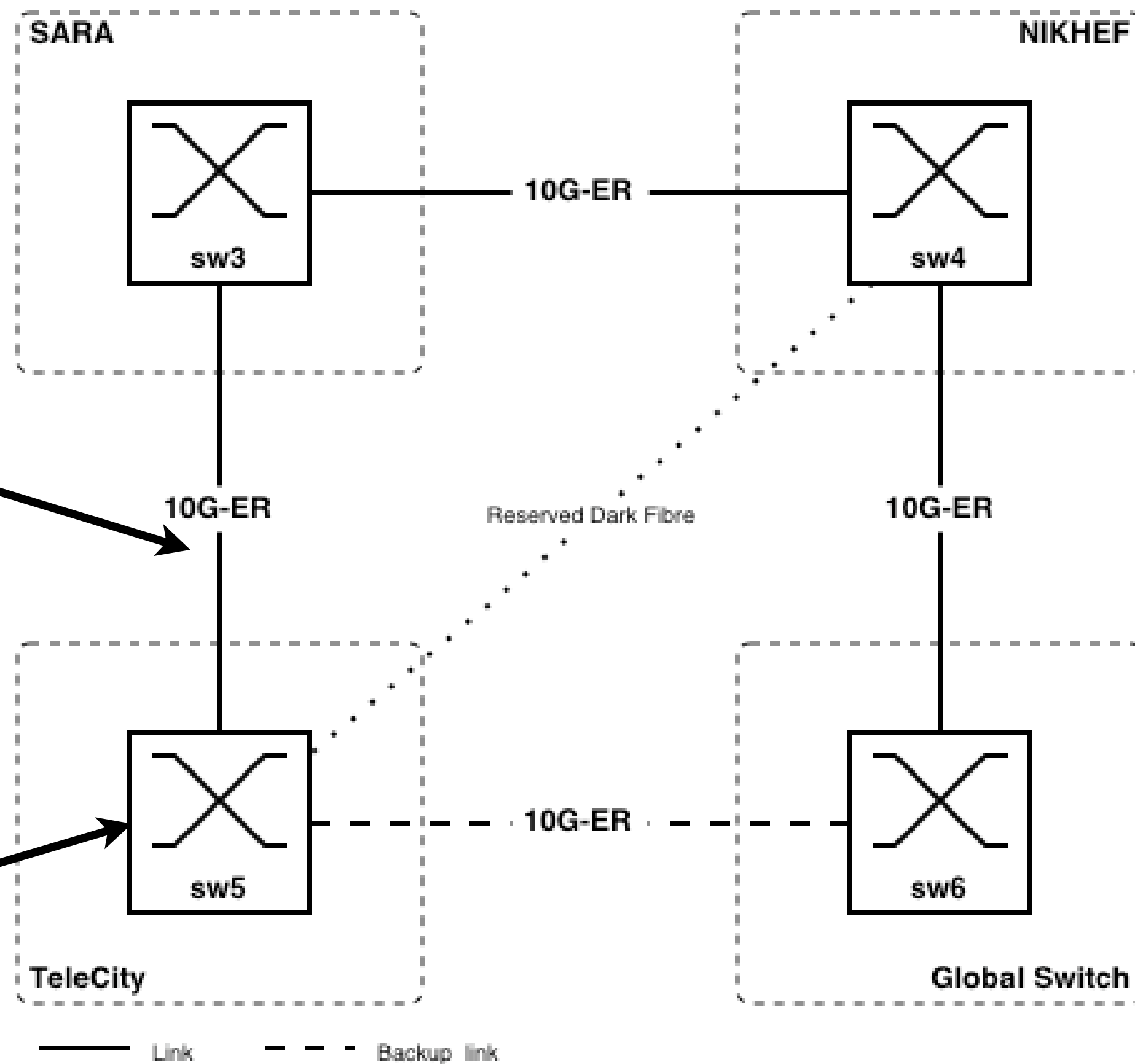

AMS-IX Platform Evolution

Version 2.0 - Q1 2001 to Q4 2003



(R)STP loop protection protocol

Backbone links upgraded from GE to 10GE End 2002

End 2003 Upgrade to BI-15000 JetCore

235 ports total
95 GE ports < FE ports

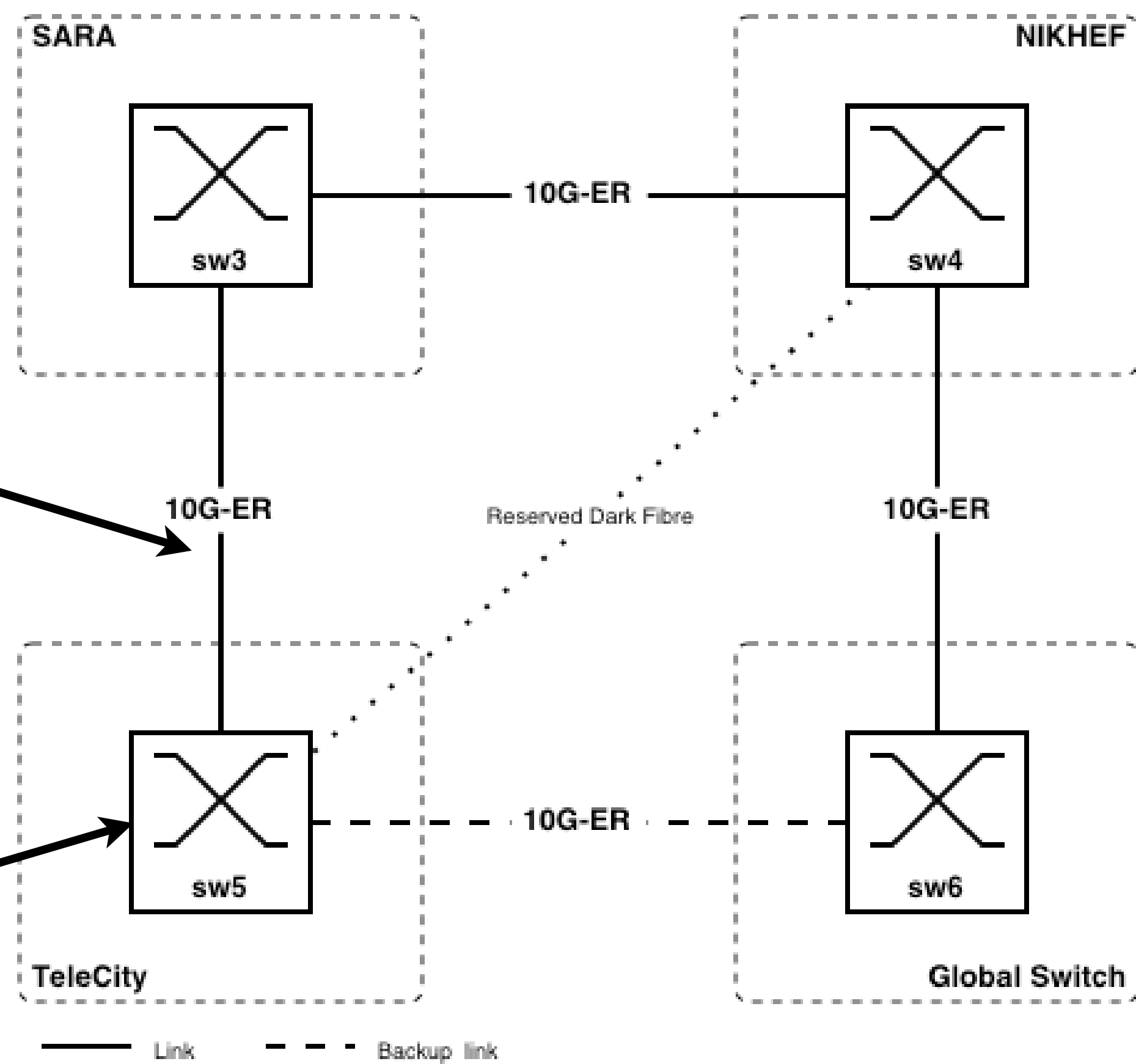

AMS-IX Platform Evolution

Version 2.0 - Q1 2001 to Q4 2003



(R)STP loop protection protocol

Backbone links upgraded from GE to 10GE End 2002

End 2003 Upgrade to BI-15000 JetCore

235 ports total
95 GE ports < FE ports

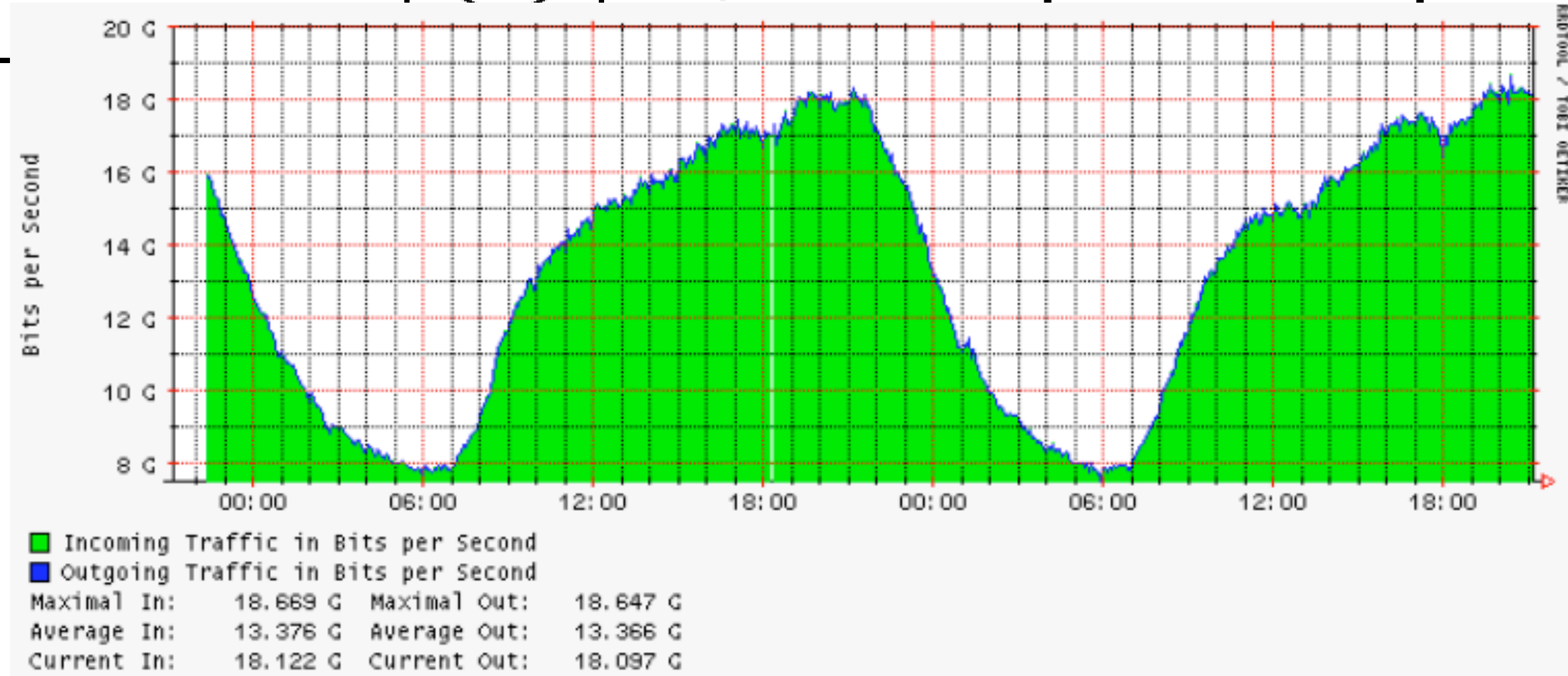
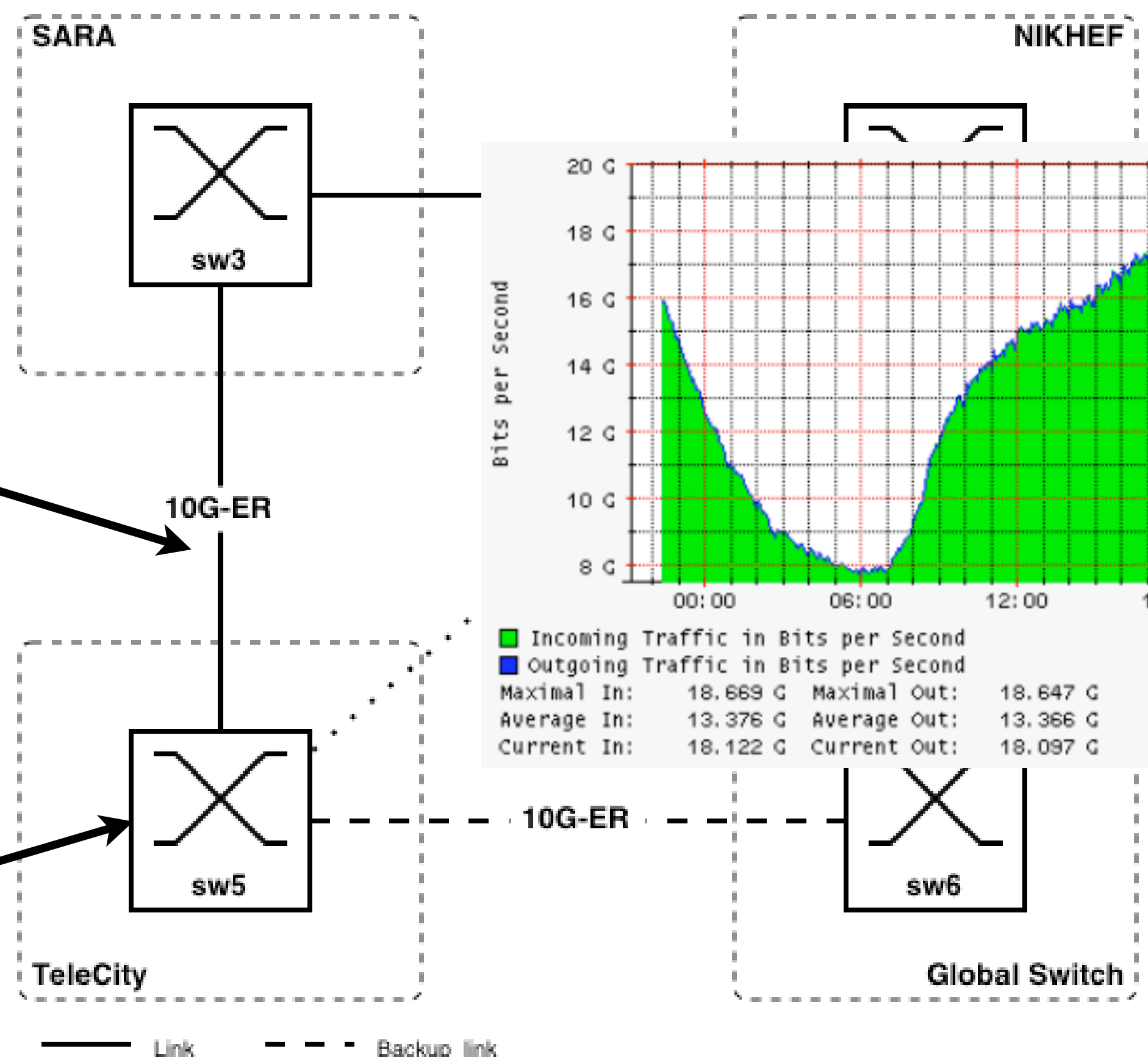

AMS-IX Platform Evolution

Version 2.0 - Q1 2001 to Q4 2003



(R)STP loop protection protocol

Backbone links upgraded from GE to 10GE End 2002

End 2003 Upgrade to BI-15000 JetCore

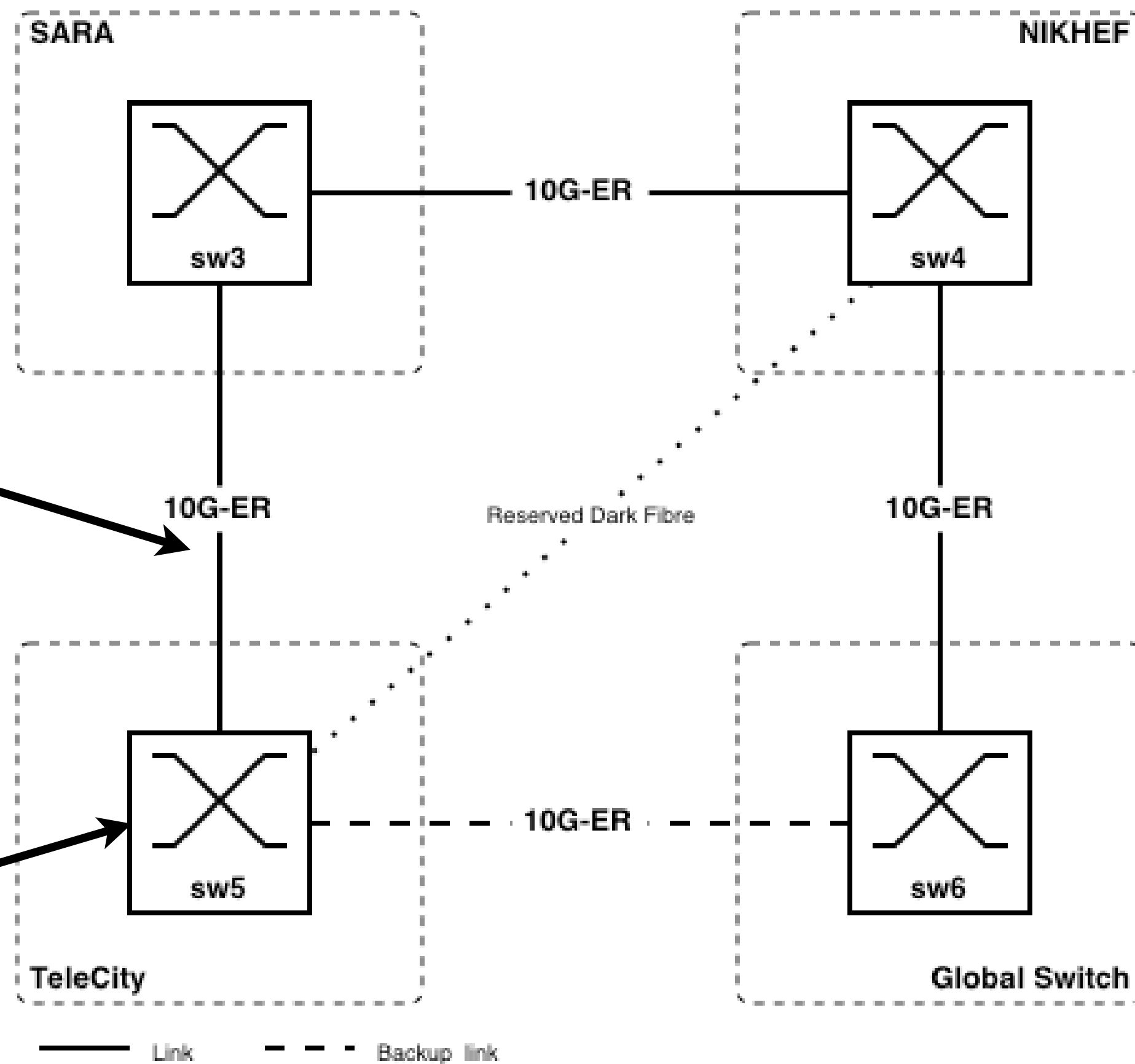

235 ports total
95 GE ports < FE ports

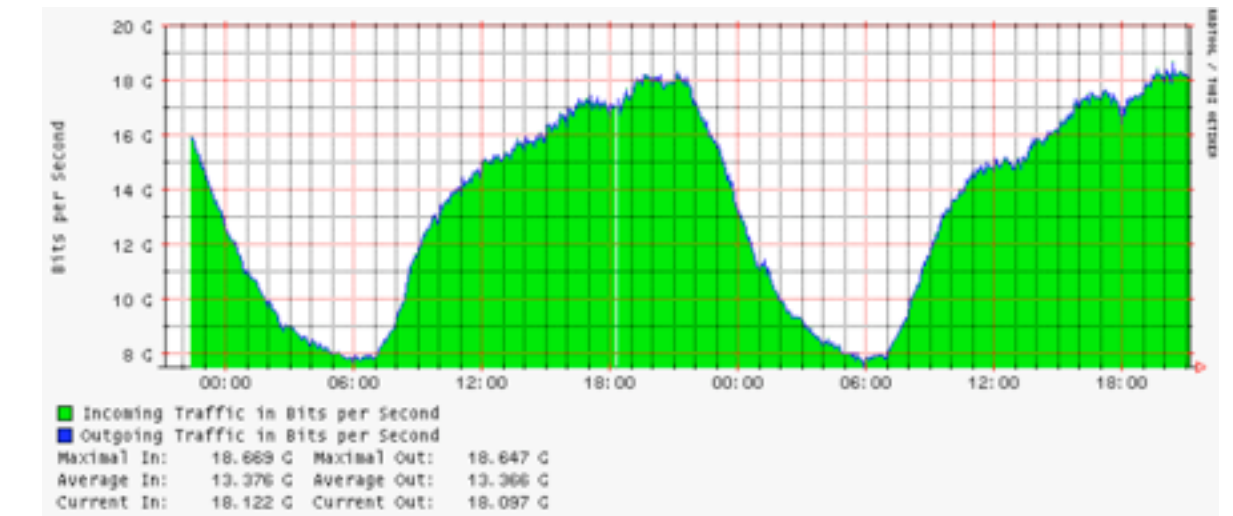

AMS-IX Platform Evolution

Version 2.0 - Q1 2001 to Q4 2003



Double Star topology:VSRP

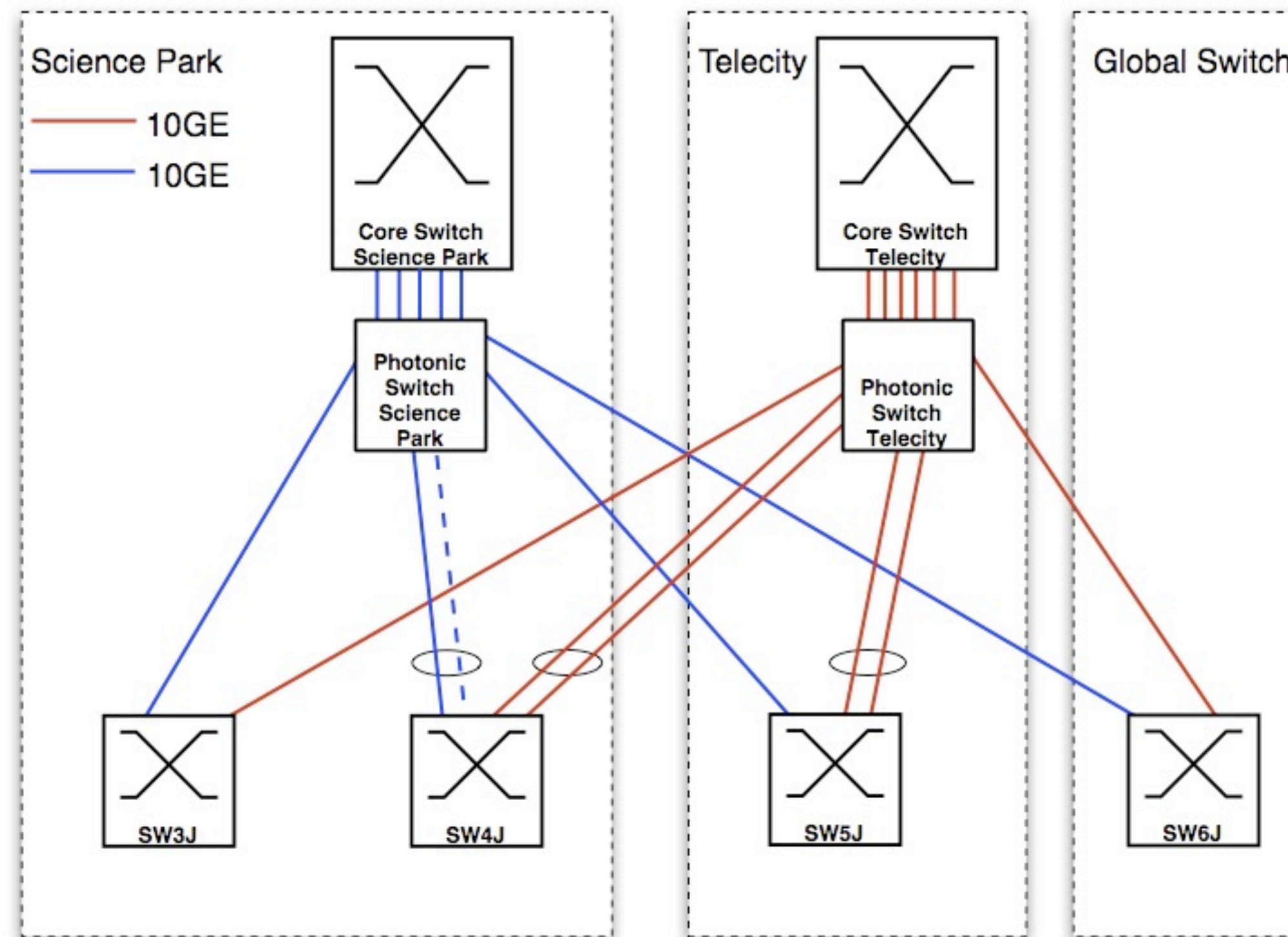

AMS-IX Platform Evolution

Version 3 Q1 2004 - Q2 2009



First Generation Core
BI-15000 JetCore

Double Star topology:VSRP

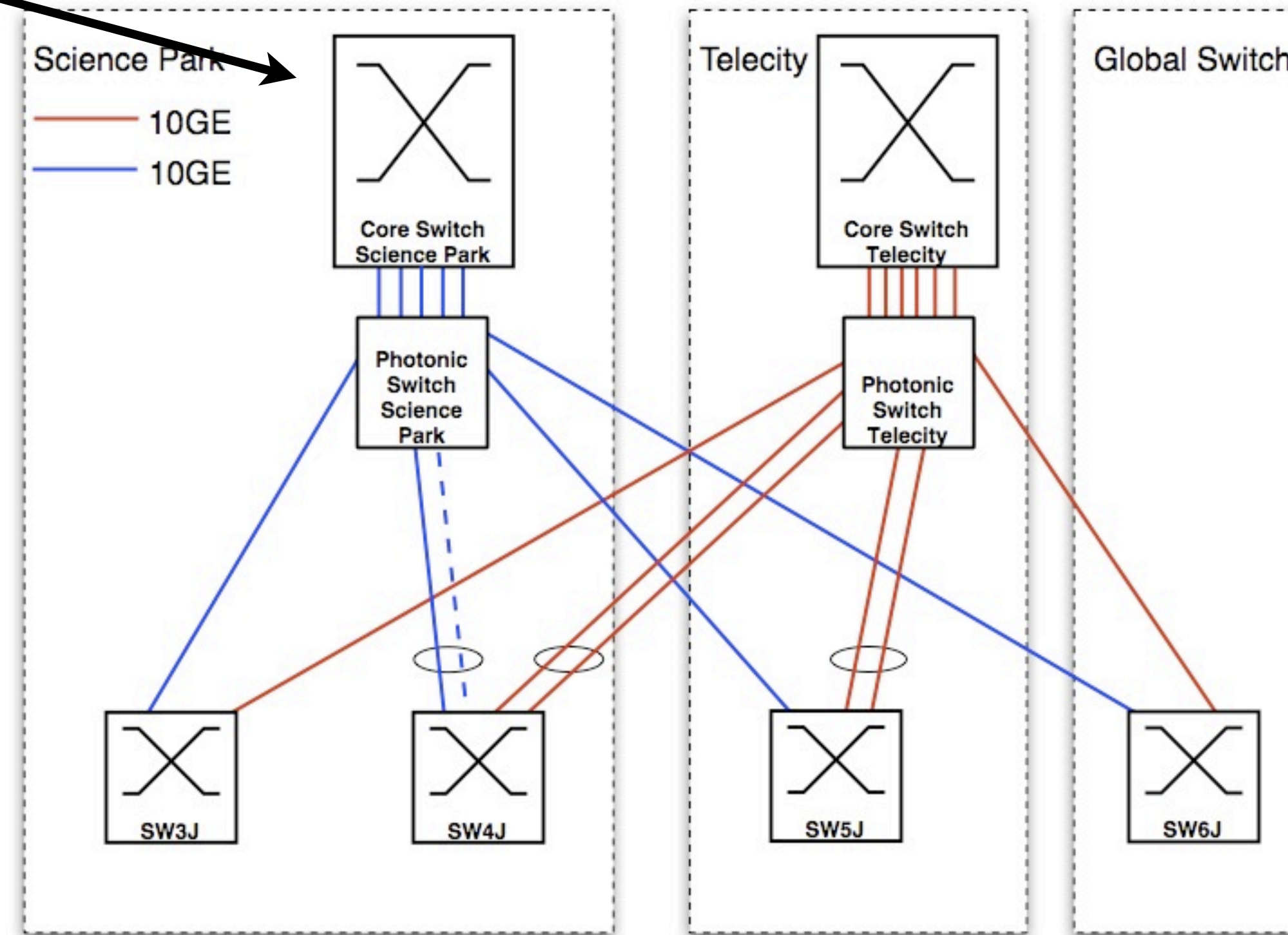

AMS-IX Platform Evolution

Version 3 Q1 2004 - Q2 2009



First Generation Core
BI-15000 JetCore

Second Generation Core
Foundry MG8

Double Star topology:VSRP

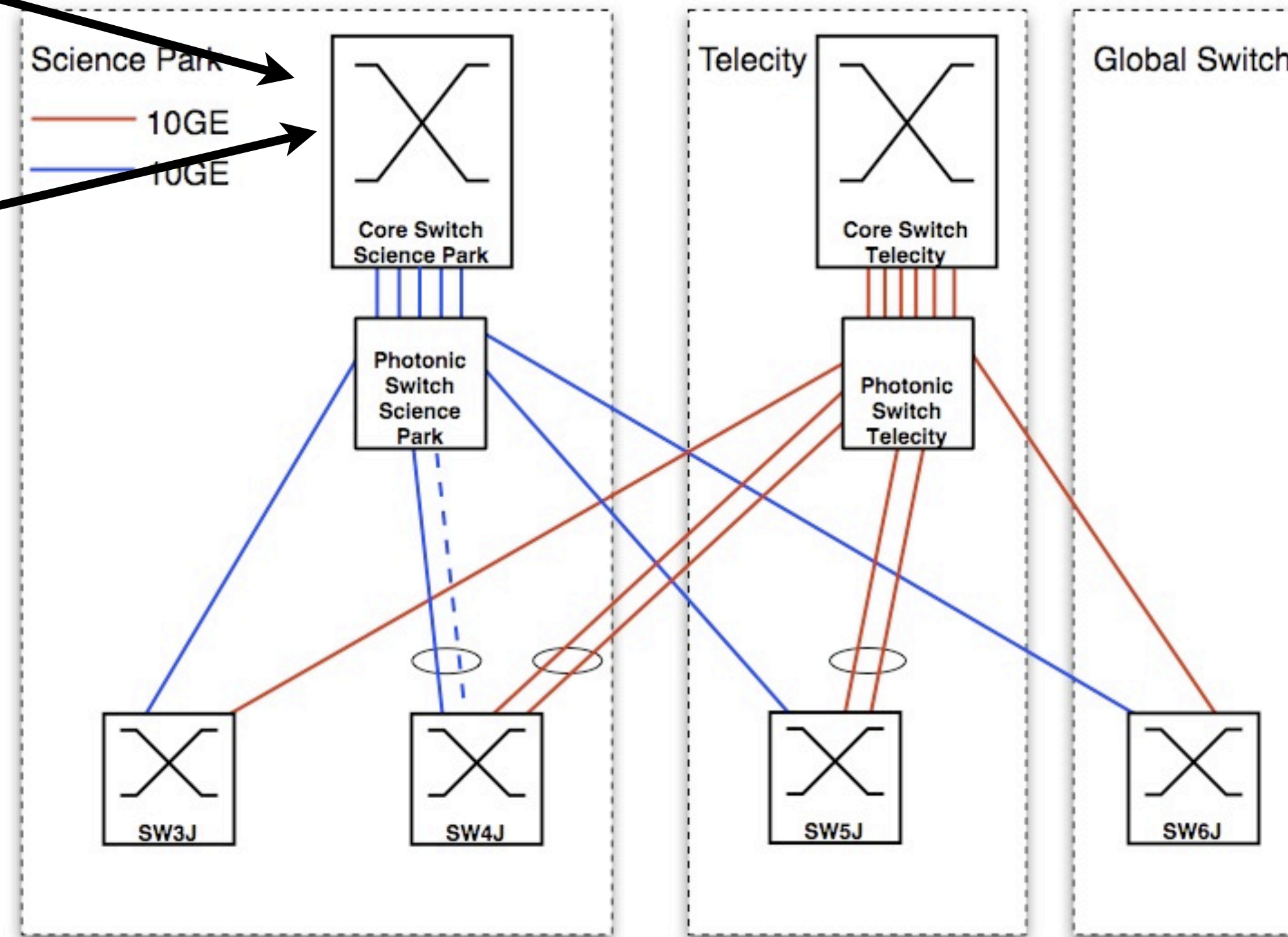

AMS-IX Platform Evolution

Version 3 Q1 2004 - Q2 2009



First Generation Core
BI-15000 JetCore

Second Generation Core
Foundry MG8

Glimmerglass
Photonic Cross Connects
Allowed for smooth
migration of ring to double
star topology

Double Star topology:VSRP

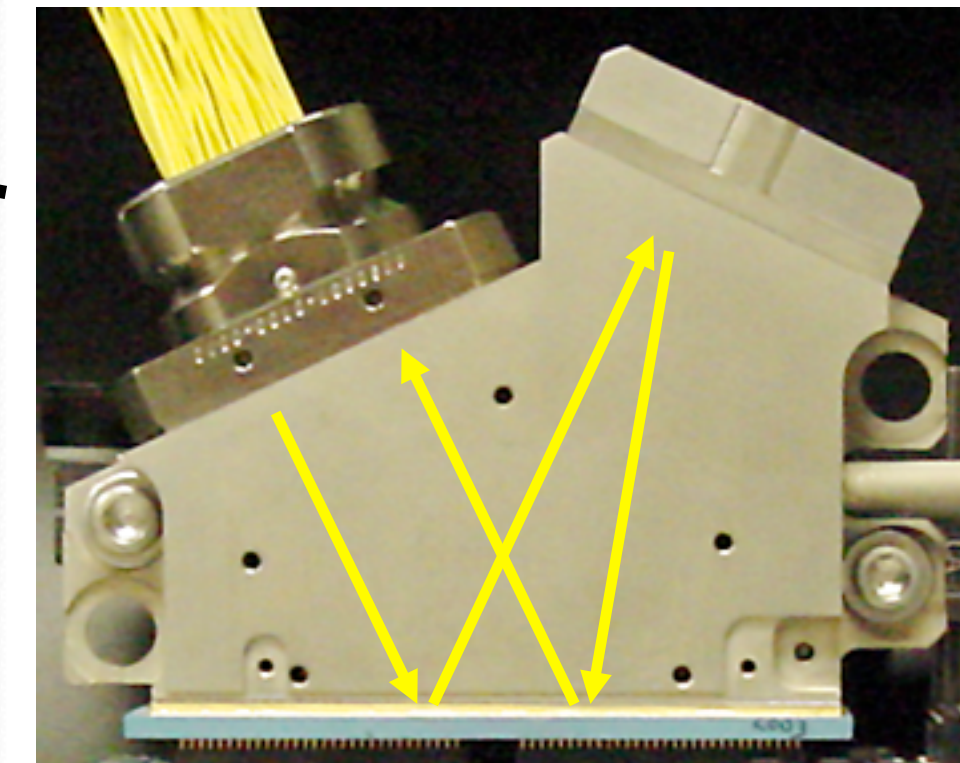
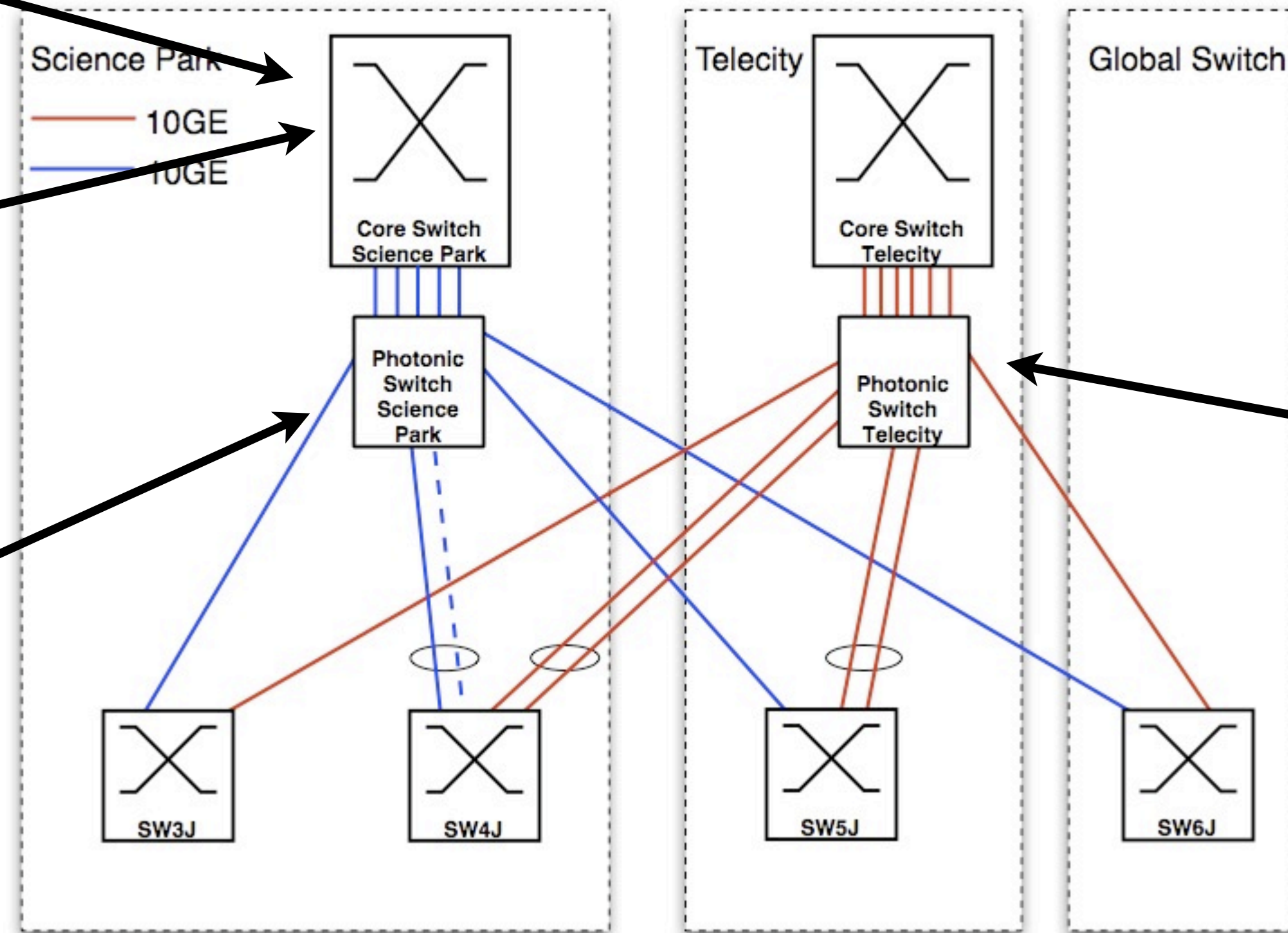

AMS-IX Platform Evolution

Version 3 Q1 2004 - Q2 2009



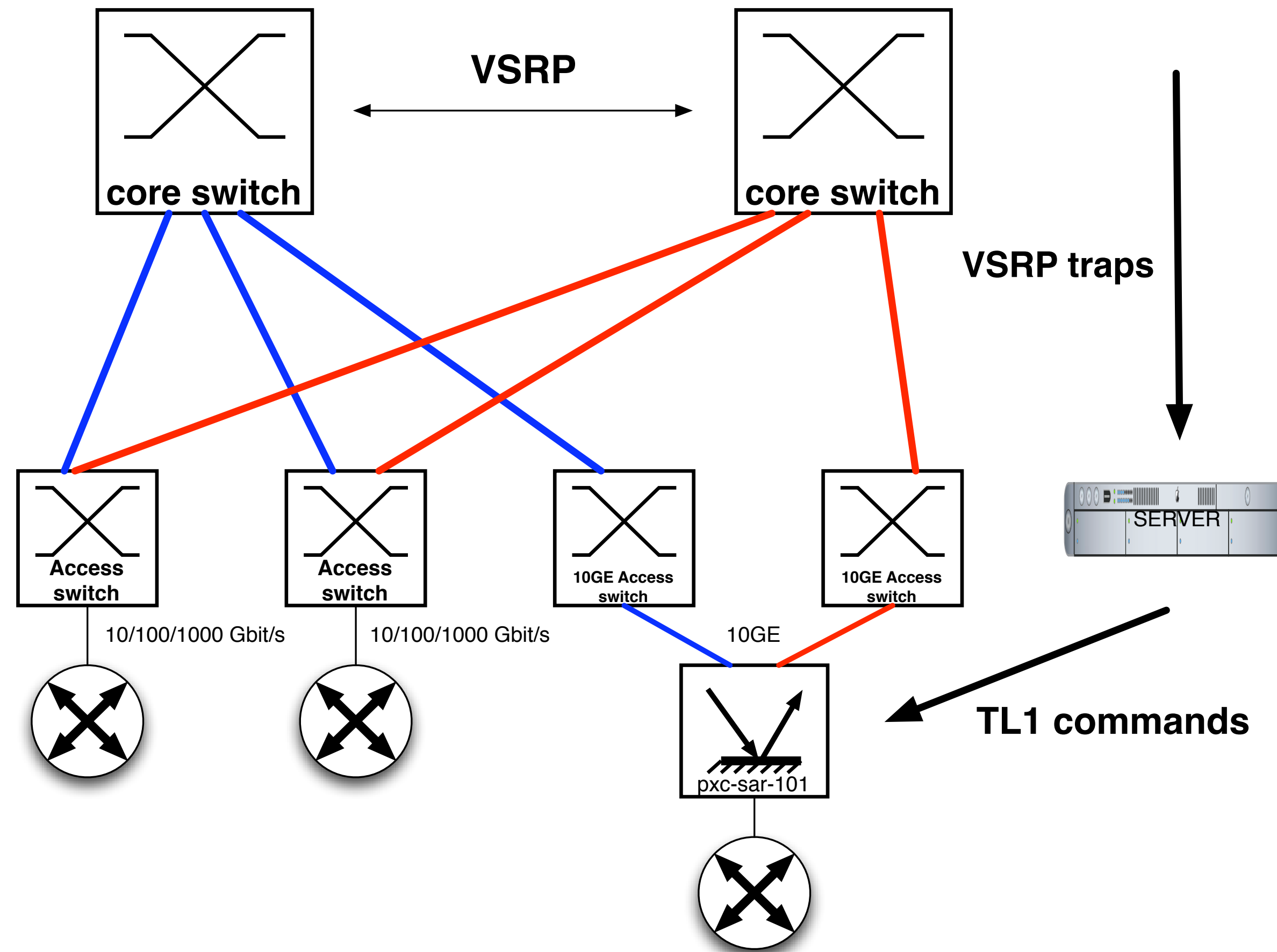

AMS-IX Platform Evolution

Version 3 Q1 2004 - Q2 2009



Dec 2003 introduction
first customer GE aggregate

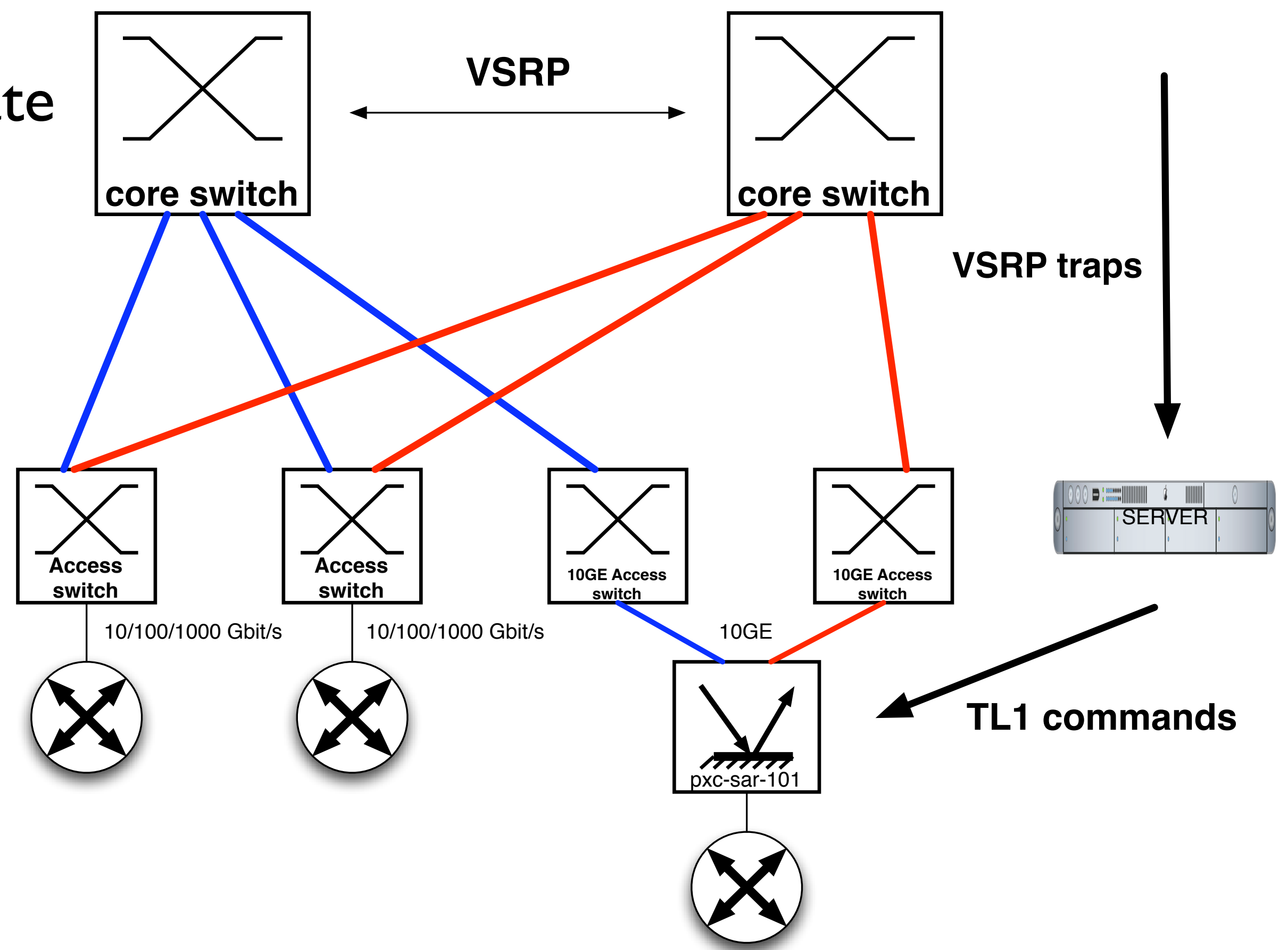

AMS-IX Platform Evolution

Version 3 Q1 2004 - Q2 2009



Dec 2003 introduction
first customer GE aggregate

Q4 2004 First 10GE
customer ports directly
on the core via PXC
VSRP traps drive PXC
failover

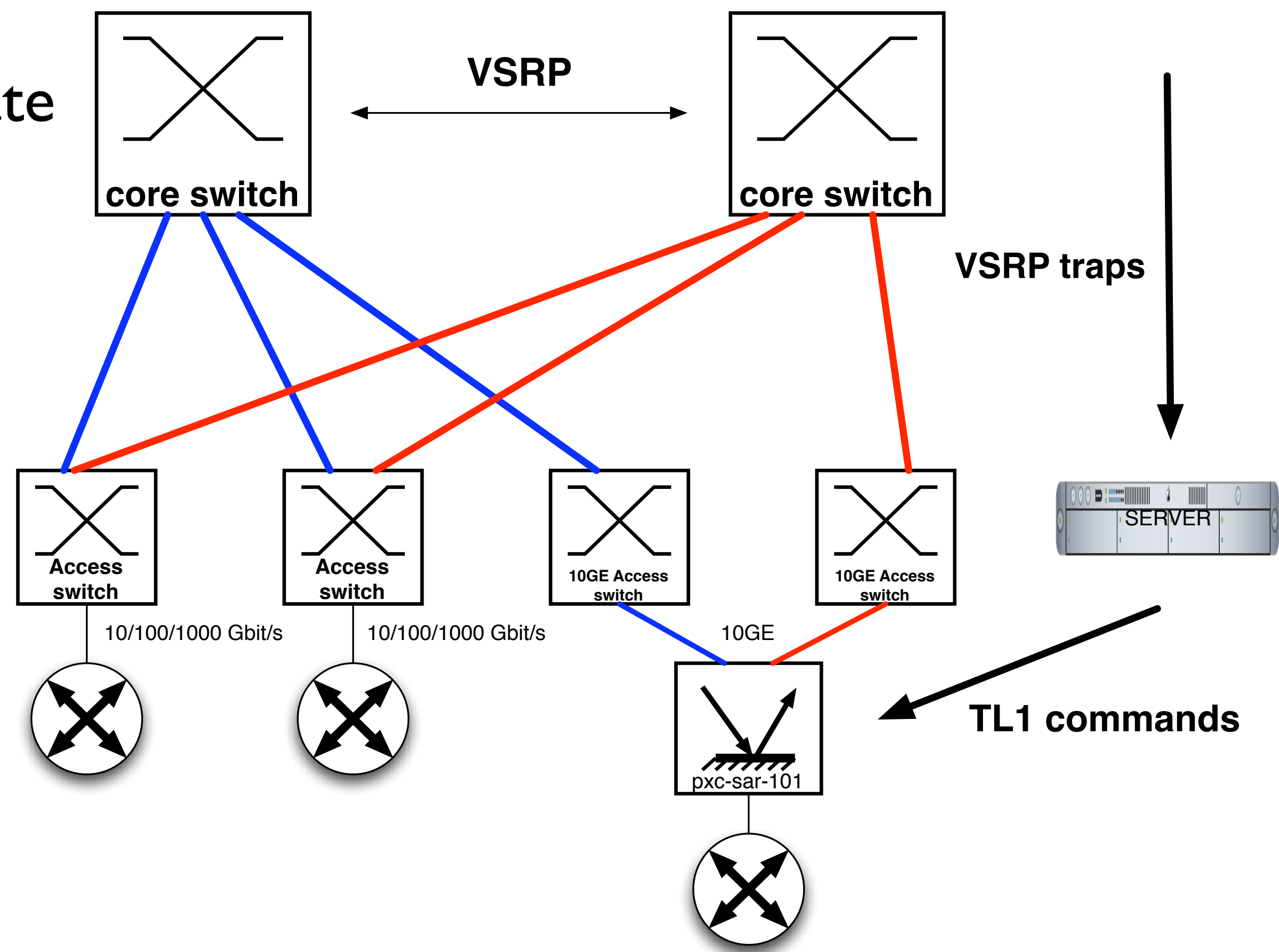

AMS-IX Platform Evolution

Version 3 Q1 2004 - Q2 2009



Dec 2003 introduction
first customer GE aggregate

Q4 2004 First 10GE
customer ports directly
on the core via PXC
VSRP traps drive PXC
failover

Ports Q2 2005

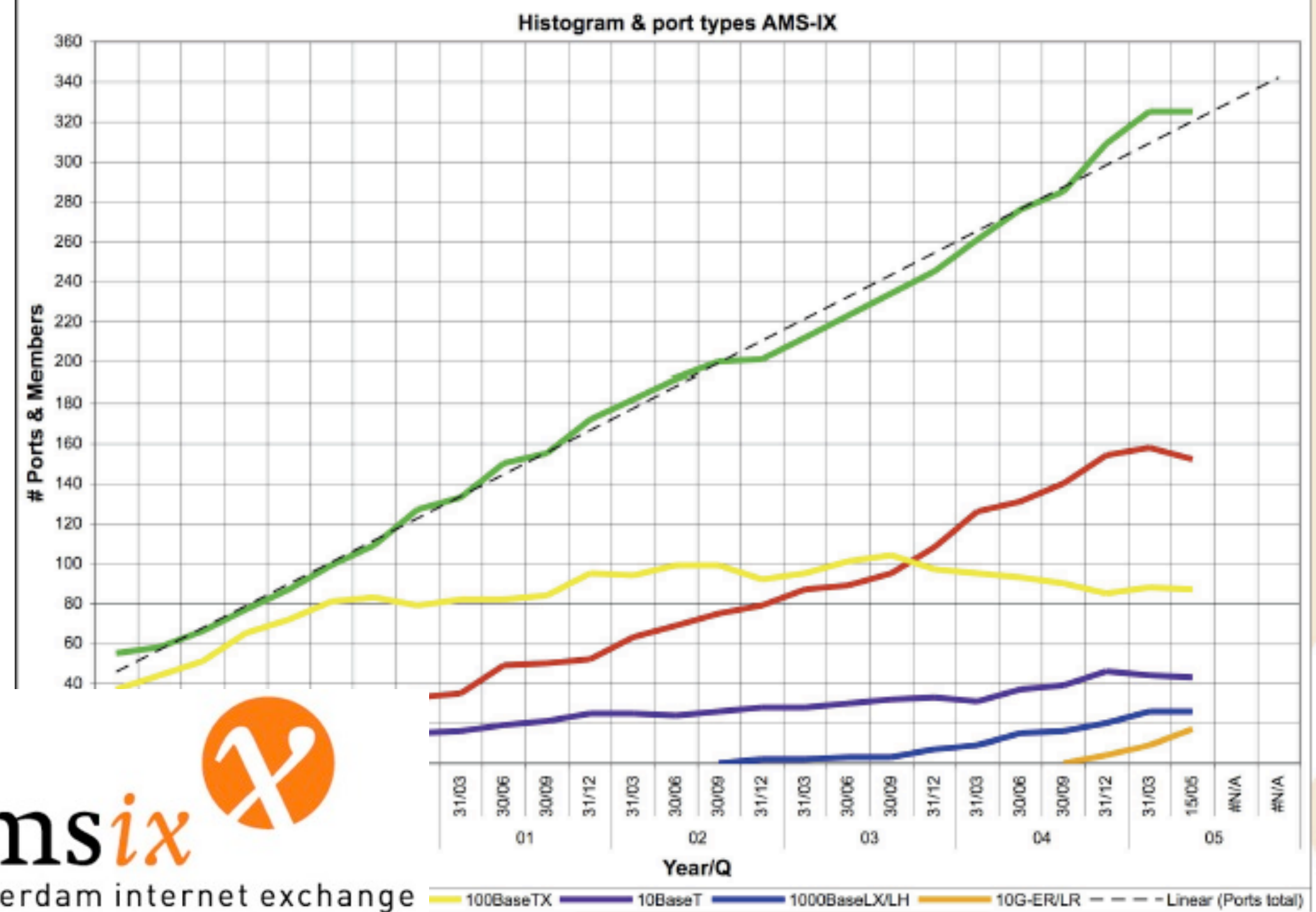
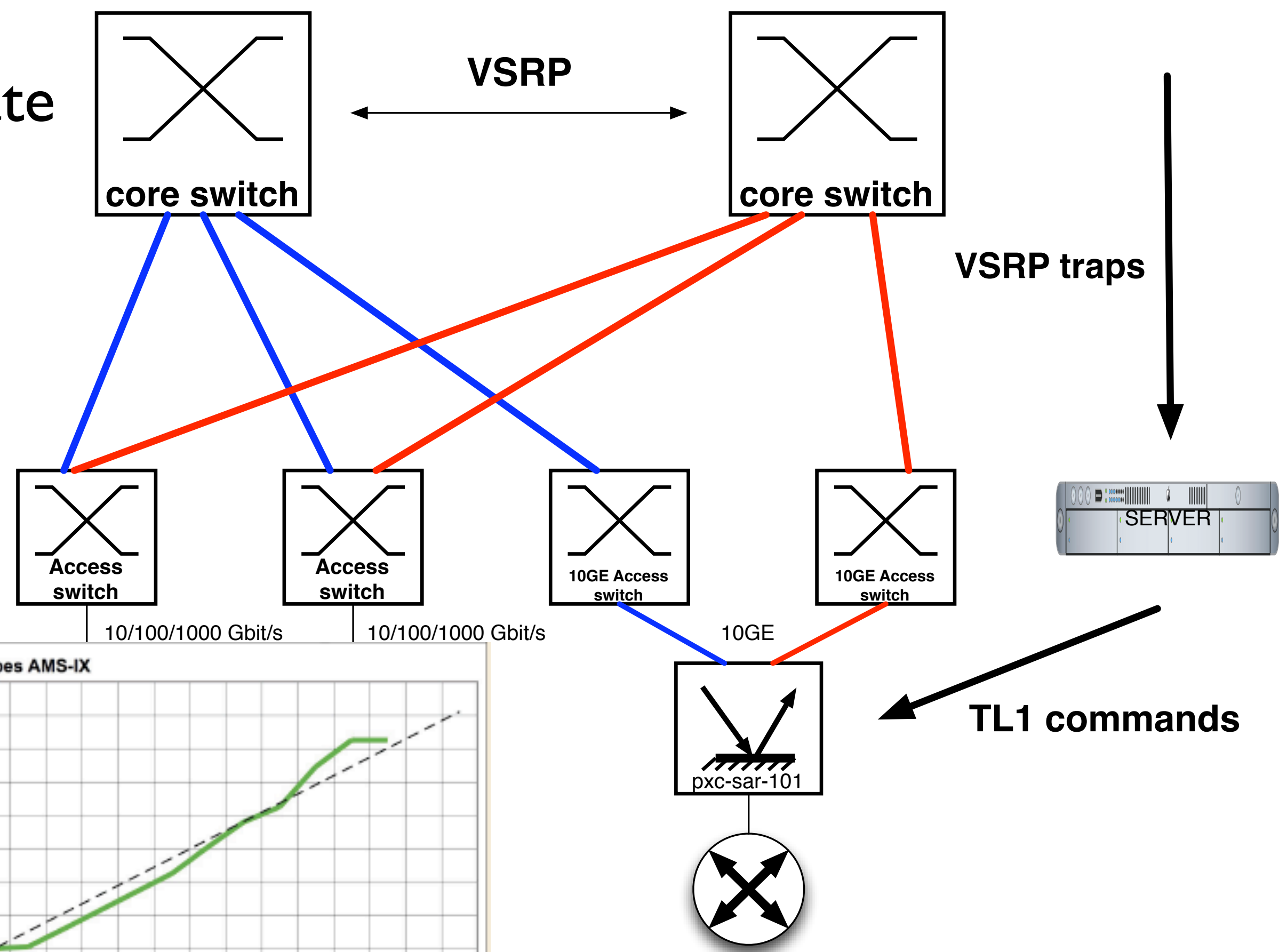

Form Evolution
2004 - Q2 2009



Dec 2003 introduction
first customer GE aggregate

Q4 2004 First 10GE
customer ports directly
on the core via PXC
VSRP traps drive PXC
failover

Ports Q2 2005

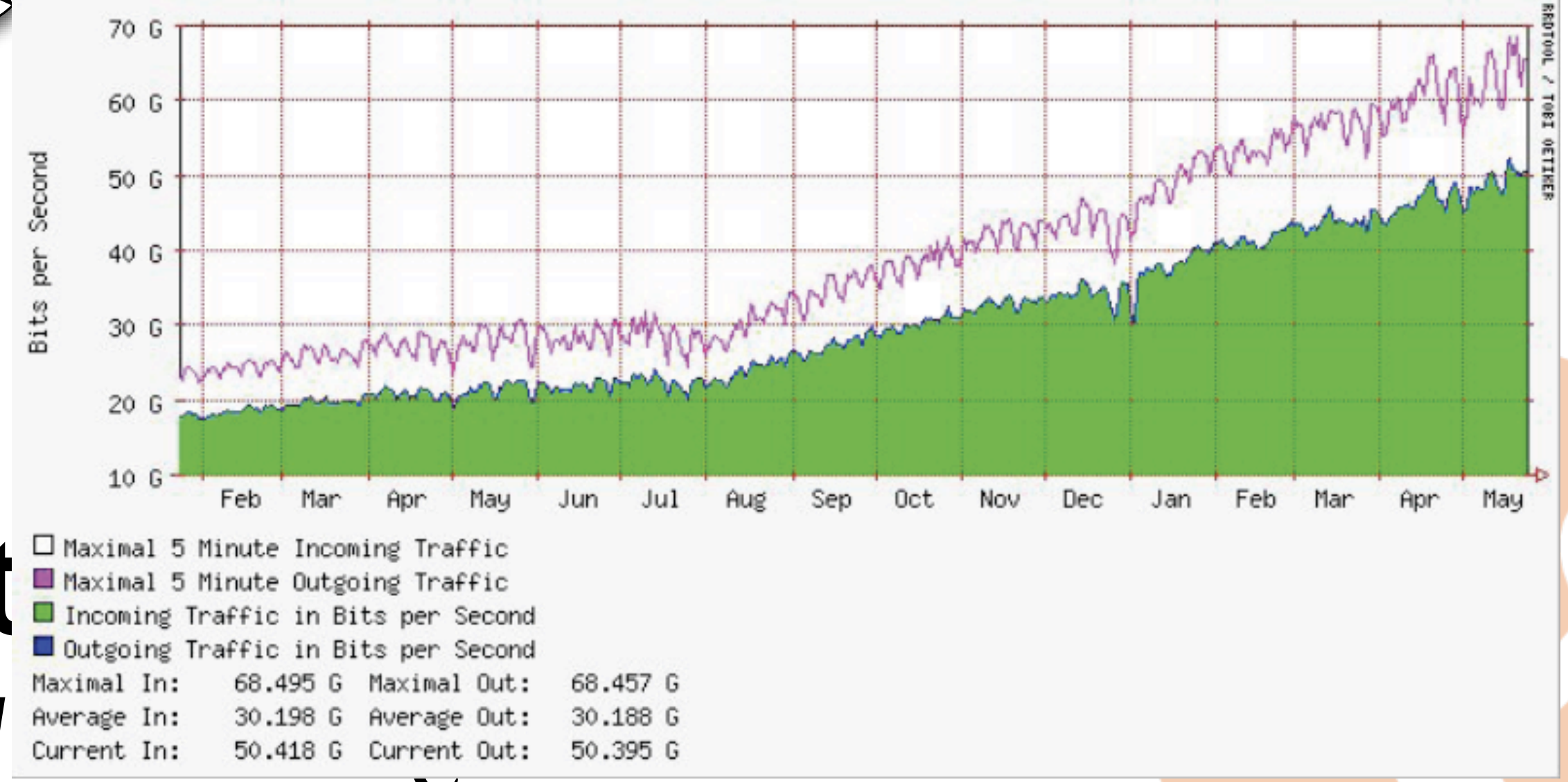
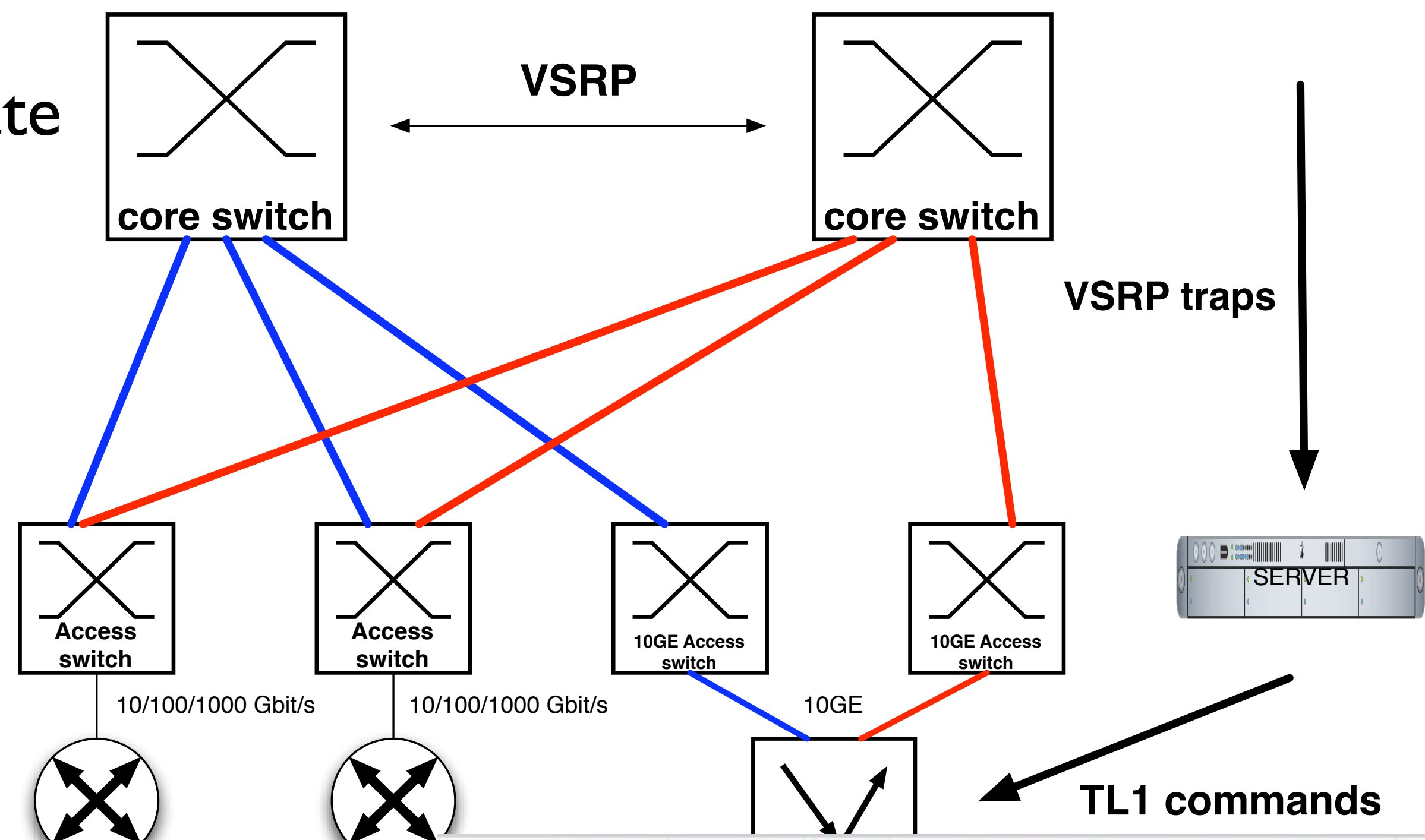
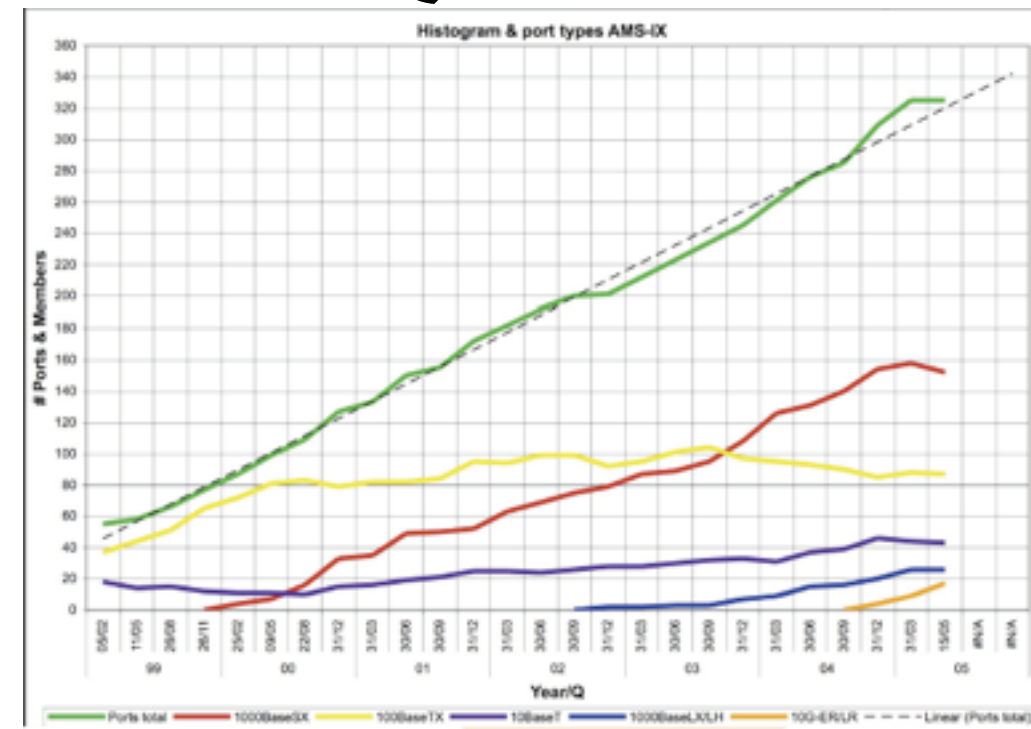

AMS-IX Platform

Version 3 Q1



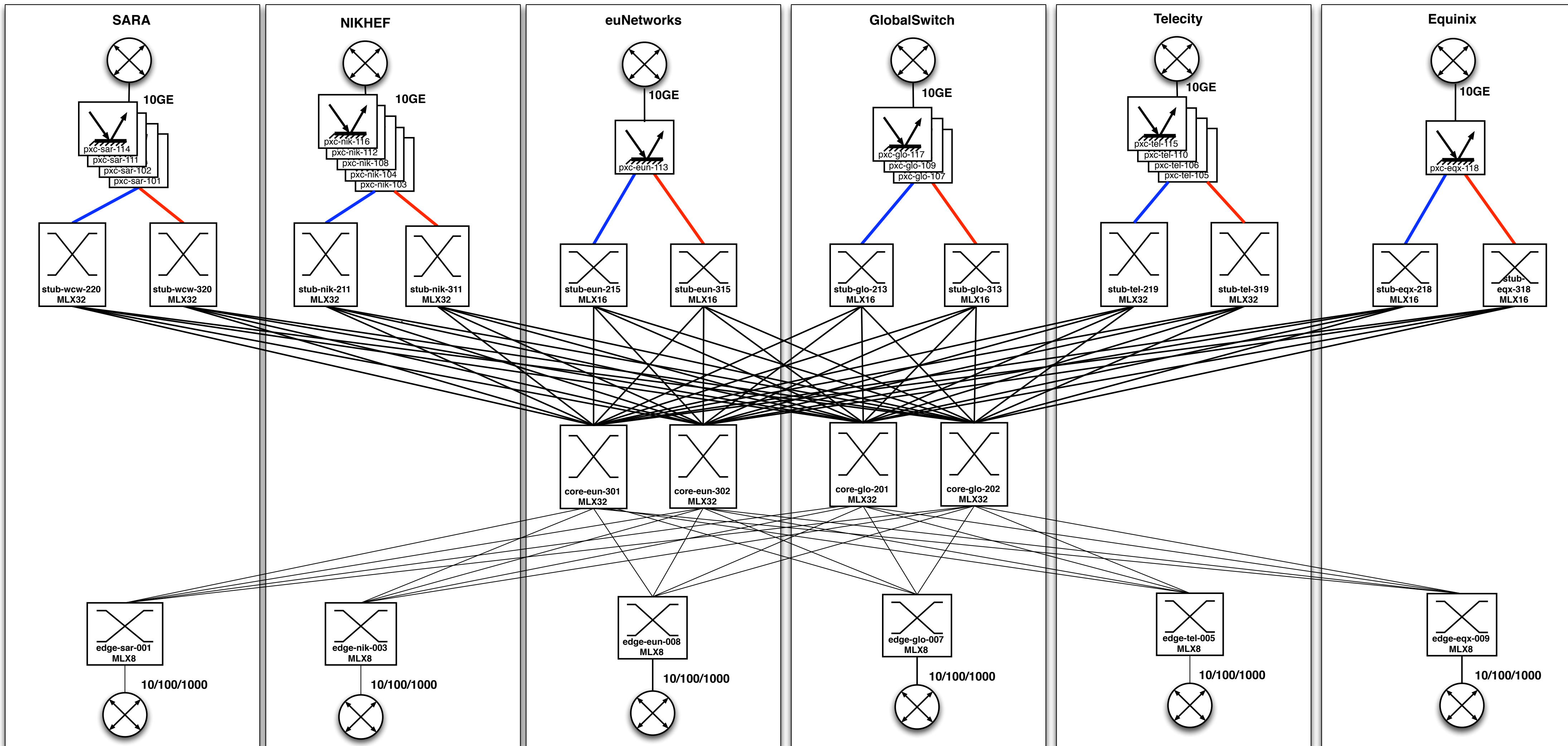

AMS-IX Platform Evolution

Version 4 Layer 1



AMS-IX Platform Evolution

Version 4 In Short

- ▶ Single hardware platform
 - ▶ Brocade (former Foundrynetworks) MLX
 - ▶ Four core switches (MLX32) used in parallel
 - ▶ Edge switches (E, FE, GE) upgraded to MLX8
 - ▶ 10GE access switches (stub) MLX16 or MLX32
- ▶ MPLS/VPLS
 - ▶ Core switches P routers (initially 4)
 - ▶ 4 LSPs from each PE to each other PE, One over each core
 - ▶ Traffic load balanced over all LSPs
 - ▶ LSP failure => automatic redistribution of traffic
- ▶ Glimmerglass Networks



Questions ?

